



**JUKI**  
*Union Special*

Thread Trimmer, Wiper (Pneumatic, Solenoid), and Stitch Condensing

**MFC7000 Series**

**UT1, UT2, UT3, UT4, UT5, UT6, SC1**

## **ADJUSTING INSTRUCTIONS & DEVICE PARTS LIST**

From the library of: Diamond Needle Corp

### **HOW TO MAKE USE OF THIS PARTS LIST**

1. Codes on the "Amt. Req." column
  - Each numeral indicates the number of parts required.
  - "0.1" and "2.5" indicate the length (in meters) of the respective parts.
2. Parentheses mean that the corresponding part is a subpart that constructs an assembly part.
3. Dotted lines on the Figures indicate assembly parts.

# Adjusting Instructions and device Parts Manual PT0110 for Devices UT1, UT2, UT3, UT4, UT5, UT6, SC1

First Edition Copyright 2001 by Union Special Corporation  
Rights Reserved In All Countries Printed in U.S.A. August 2001

## PREFACE

This parts manual has been prepared to assist you in locating NEW individual parts or assemblies on the MFC7000 Series machines. It can be used in conjunction with Union Special Parts Manuals PT0108 & Operator's Manual OP0113.

It is the desire of Union Special that each machine run at its optimum performance. Parts listed in this manual are designed specifically for your machine and are manufactured with utmost precision to assure long lasting service.

This manual has been comprised on the basis of available information. Changes in design and/or improvements may incorporate a slight modification of configuration in illustrations or part numbers.

---

## SAFETY RULES

1. Before putting the machines described in this manual into service, carefully read the instructions. The starting of each machine is only permitted after taking notice of the instructions and by qualified operators.

**IMPORTANT! Before putting the machine into service, also read the safety rules and instruction from the motor supplier.**

2. Observe the national safety rules valid for your country.
3. The sewing machines described in this instruction manual are prohibited from being put into service until it has been ascertained that the sewing units which these sewing machines will be built into, have conformed with the EC Council Directives (89/392/EEC, Annex II B).

Each machine is only allowed to be used as foreseen. The foreseen use of the particular machine is described in paragraph "STYLES OF MACHINES" of this instruction manual. Another use, going beyond the description, is not as foreseen.

4. All safety devices must be in position when the machine is ready for work or in operation. Operation of the machine without the appertaining safety devices is prohibited.
5. Wear safety glasses.
6. In case of machine conversions and changes all valid safety rules must be considered. Conversions and changes are made at your own risk.
7. The warning hints in the instructions are marked with one of these two symbols:



8. When doing the following the machine has to be disconnected from the power supply by turning off the main switch or by pulling out the main plug:
  - 8.1 When threading needle(s), looper, spreader etc.
  - 8.2 When replacing any parts such as needle(s), presser foot, throat plate, looper, spreader, feed dog, needle guard, folder, fabric guide etc.
  - 8.3 When leaving the workplace and when the workplace is unattended.
  - 8.4 When doing maintenance work.
  - 8.5 When using clutch motors without actuation lock, wait until the motor is stopped totally.
9. Maintenance, repair and conversion work (see item 8) must be done only by trained technicians or special skilled personnel under consideration of the instructions.
10. Any work on the electrical equipment must be done by an electrician or under direction and supervision of special skilled personnel.
11. Work on parts and equipment under electrical power is not permitted. Permissible exceptions are described in the applicable sections of standard sheet DIN VDE 0105.
12. Before doing maintenance and repair work on the pneumatic equipment, the machine has to be disconnected from the compressed air supply. In case of existing residual air pressure after disconnecting from compressed air supply (i.e. pneumatic equipment with air tank), the pressure has to be removed by bleeding.

# MFC7605A-H11-B56/PL1/UT5

Stitch Type	Code
2-Needle Bottom Cover Stitch	406
3-Needle Bottom Cover Stitch	407
2-Needle Top & Bottom Cover Stitch	602
3-Needle Top & Bottom Cover Stitch	605

Code	Destination Type
Blank	Japan
A	Western Hemisphere
U	South East Aisa
T	Europe

Stitch Length			
Code	2 Needle	3 Needle	Application
A	1.6-2.1mm (12-16 SPI)	1.6-2.1mm (12-16 SPI)	Hemmer Lapseamer
B	—	1.8-2.5mm (10-14 SPI)	Hemmer Lapseamer Collarete (C02) Universal
C	1.8-3.2mm (8-14 SPI)	2.5-3.2mm (8-10 SPI)	Hemmer Lapseamer
D	1.6-3.2mm (8-16 SPI)	1.6-3.2mm (8-16 SPI)	Elastic & Coverseam

Application	Description of Subclass	Code
Collarete	Converts to Hemming (U06) or coverseam (U03)	C02
Elastic Applications	Fabric Undertrimmer	E11
Elastic Applications	Fabric Undertrimmer, with Puller	E61
Hemming	Basic Style with Hem Guide	H01
Hemming	Puller with Rollers & Hem Guide	H11
Hemming	Left Hand Fabric Trimmer	H21
Hemming	Left Hand Fabric Trimmer with Puller	H31
Coverseam	Standard Seam Guide for Light Weight Fabrics	K01
Coverseam	Adjustable Seam Guides for Med to Heavy Weight Fabrics	K02
Universal	Coverseaming Parts Standard	U03
Universal	Hemming Parts Standard	U06

Gauge	Metric	Inches	Old
32	3.2mm	1/8"	8
40	4.0mm	5/32"	10
48	4.8mm	3/16"	*12
56	5.6mm	7/32"	*14
64	6.4mm	1/4"	*16

\*NOTE: Old coverstitch needle spacing for knitwear were actually 1/64" less than the gauge indicated.

Blank	Non Puller
PL1	Clutch Driven Rear Puller Roller With Teeth
PL1S	Clutch Driven Rear Puller with Smooth Roller

Blank	Non Device
UT1	Electromagnetic type, needle thread wiper & auto presser foot lift
UT2	Electromagnetic type, cover thread trim & auto presser foot lift
UT3	Pneumatic type, needle thread wiper & auto presser foot lift
UT4	Pneumatic type, needle thread blower & auto presser foot lift
UT5	Pneumatic type, top cover thread trimmer & auto presser foot lift
UT6	Electromagnetic type & auto presser foot Lift (Non Puller styles only)
SC1	Stitch Condensing

## CONTENTS

PREFACE .....	2
SAFETY RULES .....	3
MFC7000 SERIES NUMBERING SYSTEM .....	4
KLIPP-IT® THREAD TRIMMER INSTRUCTIONS .....	7
TENSION RELEASE (UNDERBED THREAD TRIMMER) .....	7
THREAD PULL-OFF .....	8
THREADING DIAGRAM .....	9
KLIPP-IT® THREAD TRIMMER .....	10
KLIPP-IT® THREAD TRIMMER ASSEMBLY .....	11
KLIPP-IT® THREAD TRIMMER ASSEMBLY .....	12
KLIPP-IT® THREAD TRIMMER ASSEMBLY .....	13
UPPER KNIFE AND CLAMPING SPRING .....	13
TENSION SPRING .....	13
KLIPP-IT® THREAD TRIMMER ASSEMBLY .....	14
LOWER KNIFE FRONT TO BACK .....	14
UPPER KNIFE STOP DISTANCE .....	14
KNIFE MECHANISM .....	14
GUIDE DISTANCE .....	14
KLIPP-IT® THREAD TRIMMER .....	15
ELECTROPNEUMATIC DRIVE .....	15
SETTING MICRO SWITCH FOR TRIMMER MECHANISM .....	16
MICRO SAFETY SWITCH CONNECTION .....	16
JUKI SC380 MOTOR .....	16
NEEDLE THREAD WIPER .....	17
ADJUSTING THREAD WIPER .....	18
COVER THREAD TRIMMER .....	19
NEEDLE THREAD BLOWER ASSEMBLY .....	19
AIR FLOW CONTROL .....	19
THREAD TRIMMER AND WIPER DEVICE TROUBLE SHOOTING .....	20
THREAD TRIMMER AND WIPER DEVICE TROUBLE SHOOTING (CONT) .....	21
THREAD TENSION .....	23
KLIPP-IT® THREAD TRIMMER ASSEMBLY .....	25
ELECTRIC PRESSER FOOT LIFTER ASSEMBLY .....	27
ELECTRIC THREAD WIPER ASSEMBLY .....	29
ELECTRIC DRIVE ASSEMBLY .....	31
ELECTRIC SPREADER THREAD TRIMMER ASSEMBLY .....	33
PNEUMATIC CONTROL .....	35
PNEUMATIC DRIVE DOUBLE ACTION ASSEMBLY .....	37
PNEUMATIC THREAD WIPER ASSEMBLY .....	39
PRESSER FOOT LIFTER .....	41
NEEDLE THREAD BLOWER ASSEMBLY .....	43
PNEUMATIC SPREADER THREAD TRIMMER ASSEMBLY .....	45
STITCH CONDENSING ADJUSTMENTS .....	46
STITCH CONDENSING ADJUSTMENTS .....	47
ADJUSTMENTS FOR STANDARD SEWING .....	47
ADJUSTMENTS FOR STITCH CONDENSING STITCH .....	48
ADJUSTMENTS FOR STANDARD SEWING .....	49
DIFFERENTIAL FEED ACTIVATE, AIR CYLINDER .....	51
FEED BAR ASSEMBLY .....	53
THROAT PLATE SUPPORT ASSEMBLY & AIR CYLINDER ASSEMBLY .....	55
UT1 .....	56
UT2 .....	57
UT3 .....	58
UT4 .....	59
UT5 .....	60
UT6 .....	61
SC1 .....	62
NOTES .....	63
NUMERICAL INDEX OF PARTS .....	64
NUMERICAL INDEX OF PARTS .....	65
NOTES .....	66
NOTES .....	67





**TURN OFF MAIN POWER SWITCH BEFORE WORKING! WHEN USING CLUTCH MOTORS WITHOUT ACTUATION LOCK WAIT UNTIL THE MOTOR HAS COMPLETELY STOPPED.**

### TENSION RELEASE (UNDERBED THREAD TRIMMER)

Set separators (C) as close to tension discs (D) without touching them and not to bind when fully extended.

Tension discs (D) must open as soon as cutting process begins.

Tension disc separators (C) should move freely between tension discs (D) without binding.

Thread trimmer and tension release assemblies are linked together.

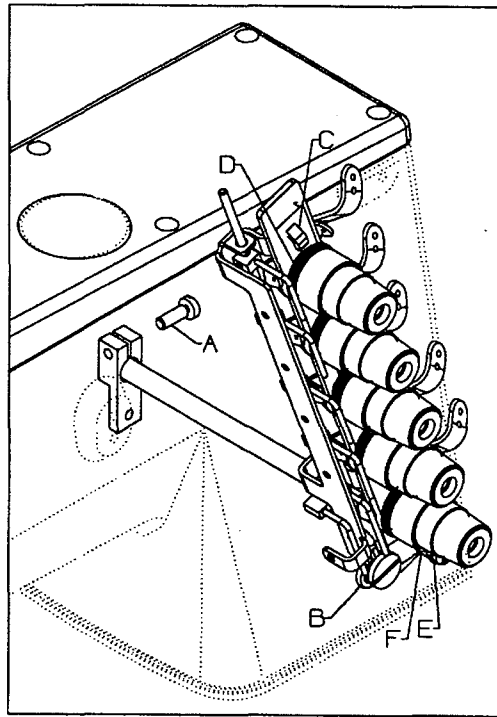

**Fig 1**

TO ADJUST:

Loosen screw (E).

Turn eccentric (F), located behind screw (E) to set tension release lever (B) as required.(Fig 1)

Retighten screw (E).

After adjustment there should be no binding at any point.

Adjust the tension release lever (A) to fully open the tension release and return without binding. The tension release is timed with the activation of the fabric thread trimmer.

## THREAD PULL-OFF

Pull-off hooks (F) for needle threads, control length of needle thread tails on a garment after trimming.

Set hooks (F) to strike-off shortest tail possible and still start sewing within the first or second stitch.

Set thread pull-off hook (G), for spreader thread so that thread is clamped securely when trimmed and starts properly when the stitch is first started. Lowering the needle thread pull off hooks will strike off more thread leaving longer tails.

Set hook (H), for the looper thread so that the thread is clamped securely when trimmed.

NOTE: Moving strike-off hooks down strikes off more thread. Moving strike-off hooks up strikes off less thread.

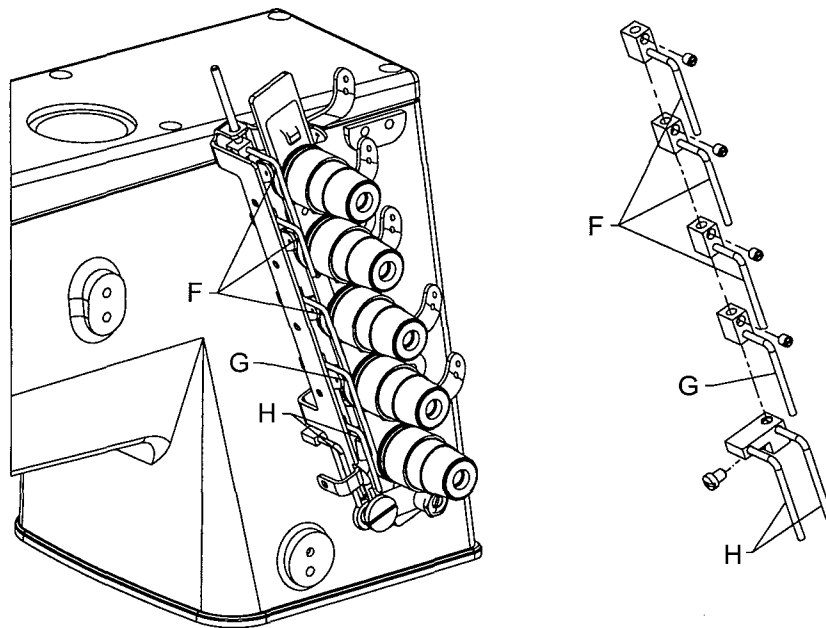



THREADING DIAGRAM  
Looper Thread Strike-Off

CAUTION: Improper threading may cause; looper thread wrap-ups or inconsistent start of stitches.

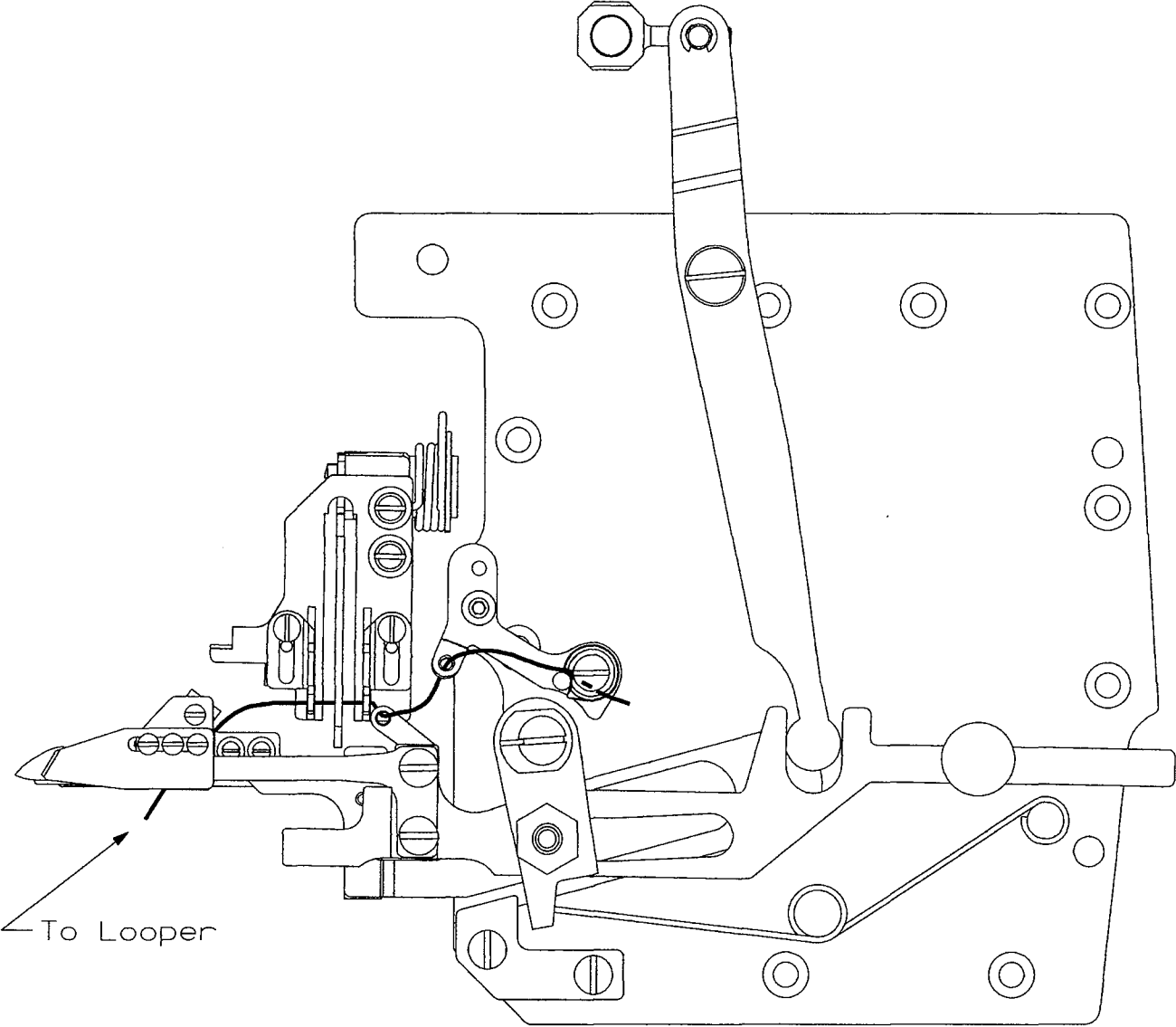

## KLIPP-IT® THREAD TRIMMER

Set stroke of the knife drive to: 18mm (45/64"). All gauges.

Remove the cloth plate.

Loosen nut (A).

Move crosshead (B) on shaft (C) as required.

Retighten nut (A).

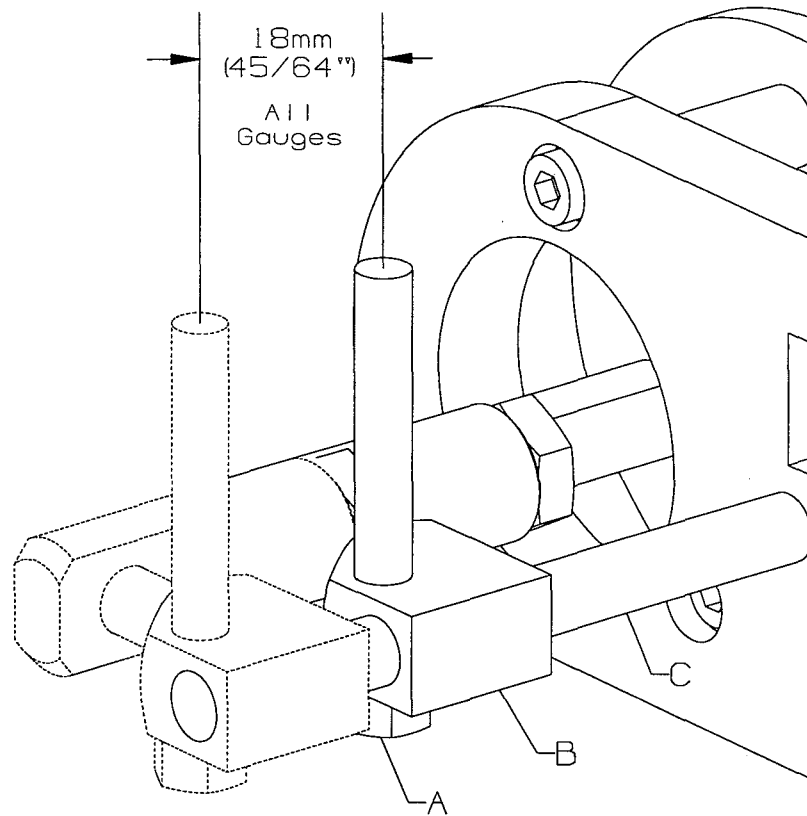

## KLIPP-IT® THREAD TRIMMER ASSEMBLY

When the thread trimmer is in its home position, the distance between rear of lower knife (L) and the protruding edge of lever (D) should be: 0.4mm(1/64").

Remove retainer ring (E).

Push down on driving link (F) to remove from hole in arm (G).

Turn driving link(F) in or out as required.

Release driving link (F) making sure pin is in hole in arm (G).

Replace retainer ring (E).



**SPRING (AA) MUST BE IN POSITION AT ALL TIMES FOR PROPER FUNCTION.**

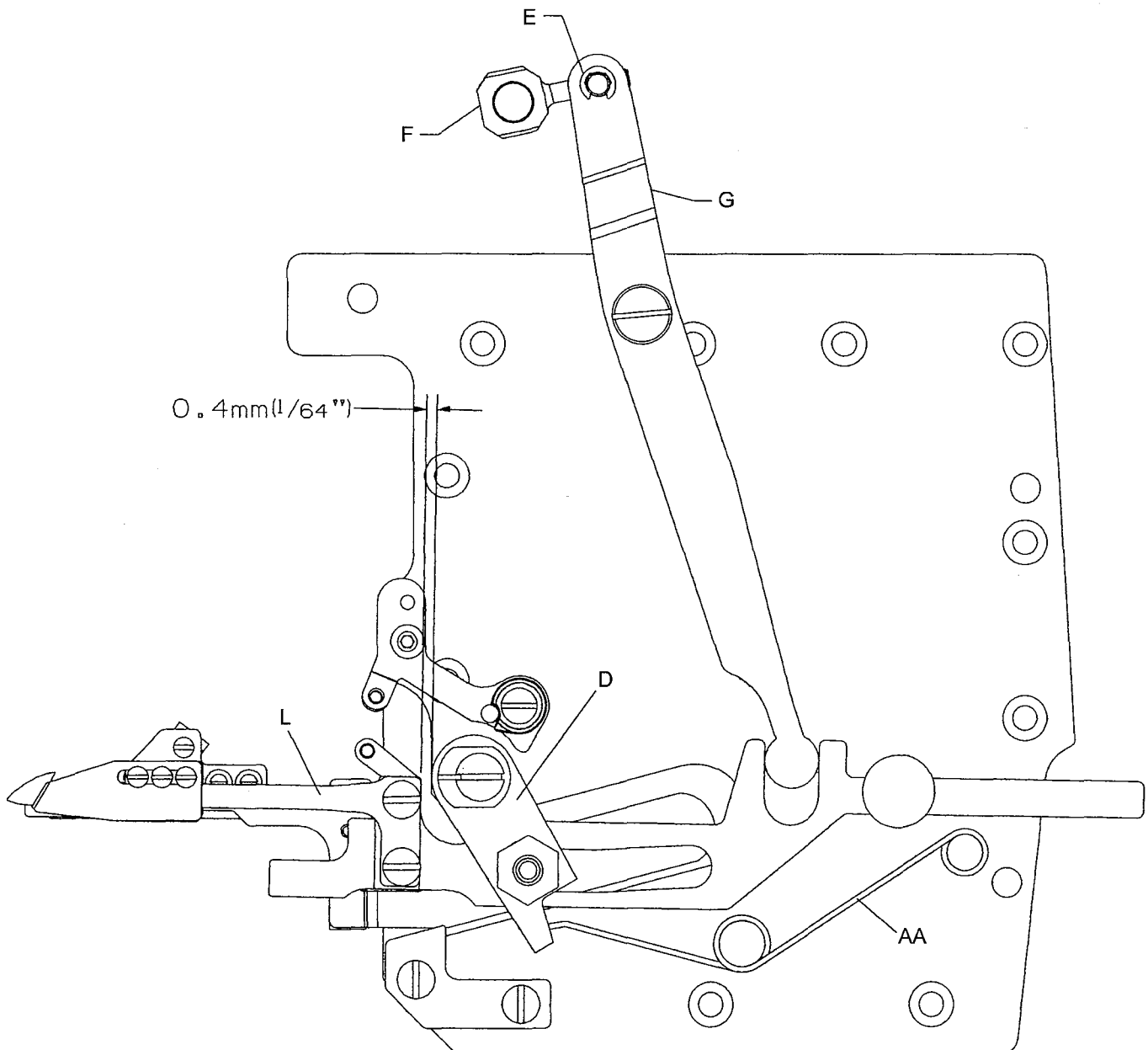

# KLIPP-IT® THREAD TRIMMER ASSEMBLY

## Knife Adjustment

When positioning lower knife (L), eyelet (J) must be seated to the right.

Lower knife (L) must be seated to the right and all the way forward when tightened.(Fig2)

Loosen 2 screws (K).

Move eyelet (J) to the right as required.

Set lower knife as required.

Retighten screws (K).

To ensure no binds, extend knife (L) to the left and loosen upper knife screws (H,H1) at the same time.

Retighten screws (H,H1).

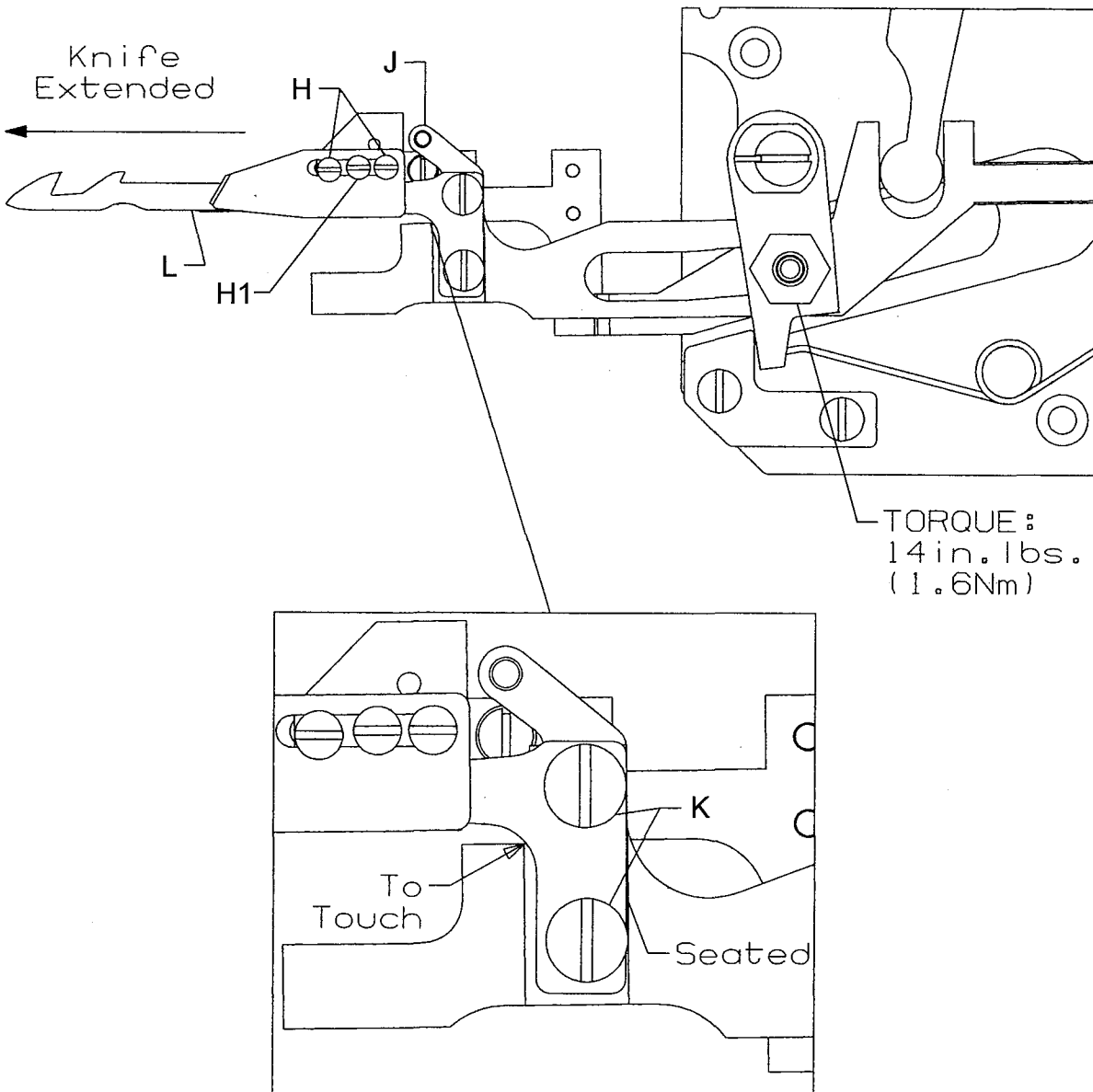

**Fig 2**

## KLIPP-IT® THREAD TRIMMER ASSEMBLY

Upper knife (M) should overlap lower knife (L) by: 0.5mm(.020").(Fig3)

The distance from clamping leaf spring (N) to the tip of lower knife (L) should be: 3.2mm(1/8"). Clamping leaf spring (N) should be flush with knife at edge.(Fig4)(Fig5)

NOTE: The clamping leaf spring must be set to only clamp the looper thread, NOT the needle threads.

The distance from tension leaf spring (P) to the back of upper knife should be: 0.5mm(.020") to 1.0mm(.040").(Fig5)

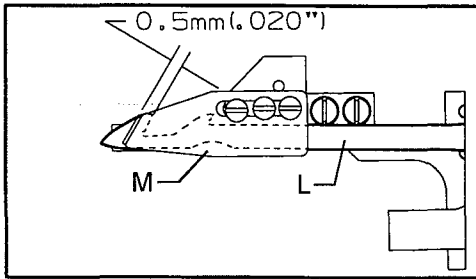

Fig 3

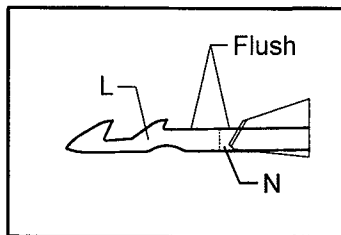

Fig 4

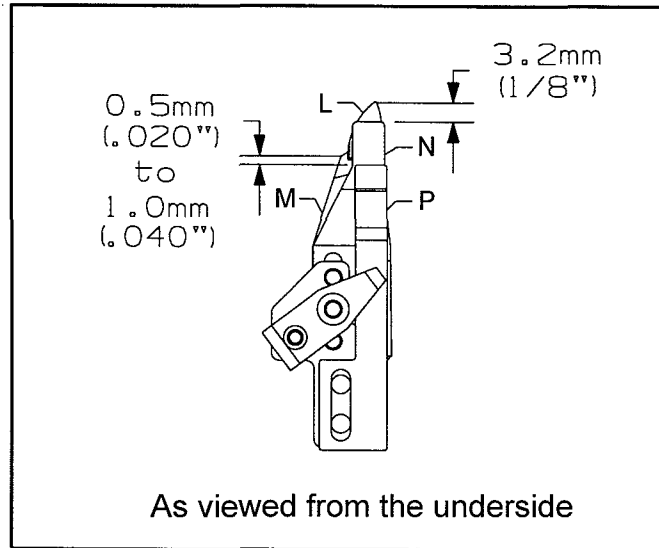

Fig 5

### UPPER KNIFE AND CLAMPING SPRING

Loosen two screws (H) and screw (H1).

Move upper knife (M) and clamping leaf spring (N) as required.

Retighten screws (H) and (H1).

To increase clamping spring tension turn screw (H1) clockwise.(Fig6)

### TENSION SPRING

Loosen two screws (Q).

Adjust leaf spring (P) as required.

Retighten screws (Q).

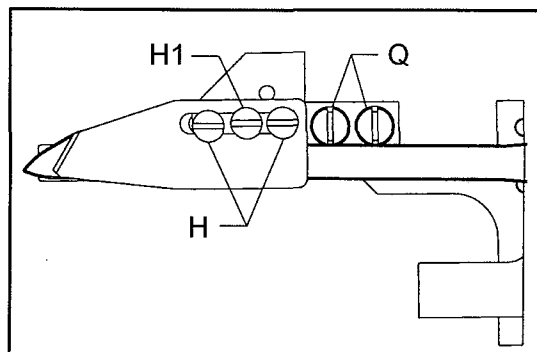

Fig 6

## KLIPP-IT® THREAD TRIMMER ASSEMBLY

With the needles at top dead center: Lower knife (L) should be extended past the heel of looper (S) by: 12.0mm(15/32"), for the following adjustments.

The tip of lower knife (L) should be centered front to back, to the rear edge of the flat on top of looper (S).

Stop (R) sets the distance of the upper knife and springs to the looper, it should be centered in its slots.

Guide (X) should just contact edge (BB) of knife mechanism.

On cover stitch machines (G) should be set slightly rearward 0.13mm(.005") of the standard adjustment.

The bottom of lower knife (L) should clear looper (S) by 0.1mm(.004").

### LOWER KNIFE FRONT TO BACK

Loosen screw (T).

Move eccentric (U) as required. NOTE: line on eccentric should always be on left side.

Retighten screw (T).

### UPPER KNIFE STOP DISTANCE

Loosen screws (V).

Move stop (R) as required.

Retighten screws (V).

### KNIFE MECHANISM

#### GUIDE DISTANCE

Loosen screws (W).

Move guide (X) as required to just contact edge (BB) as knife moves to the left.

Retighten screws (W).

Loosen screws (W). Move guide (X) as required to obtain 0.1mm(.004") dimension. Between (S) and (L).

Retighten screws (W).

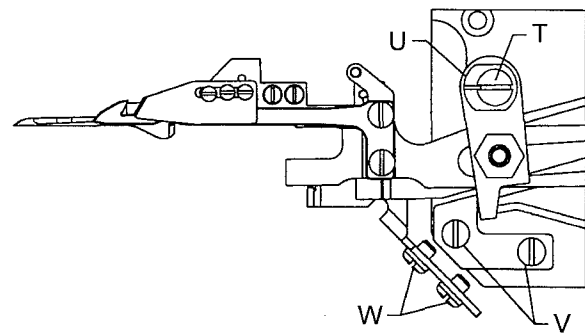
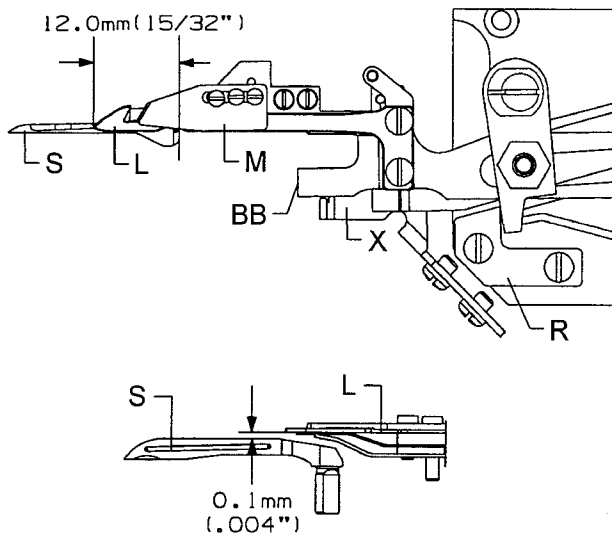

# KLIPP-IT® THREAD TRIMMER

## ELECTROPNEUMATIC DRIVE

Adjust the metering screws so that thread trimmer mechanism and knife move smoothly left to right and the threads are cleanly cut and clamped.

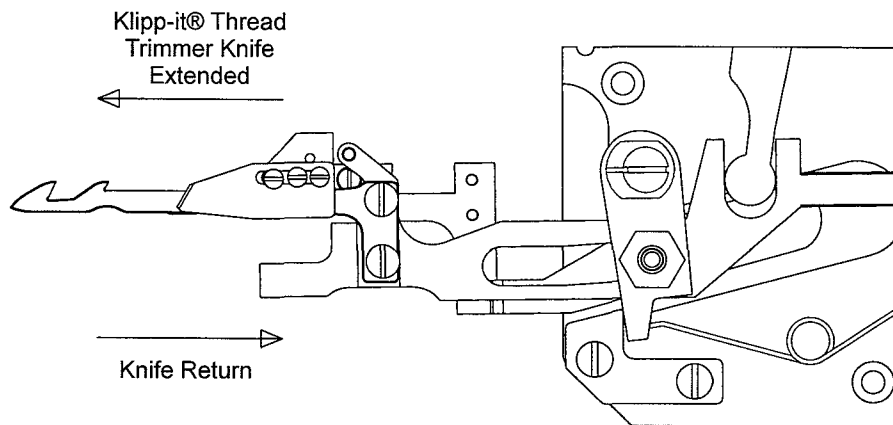

To increase the speed of the knife return, turn screw (Y) counterclockwise.

To decrease the speed of the knife return, turn screw (Y) clockwise.

To increase the speed of the knife extending, turn screw (Z) counterclockwise.

To decrease the speed of the knife extending, turn screw (Z) clockwise.

NOTE: For proper air pressure refer to pages 48 - 50.

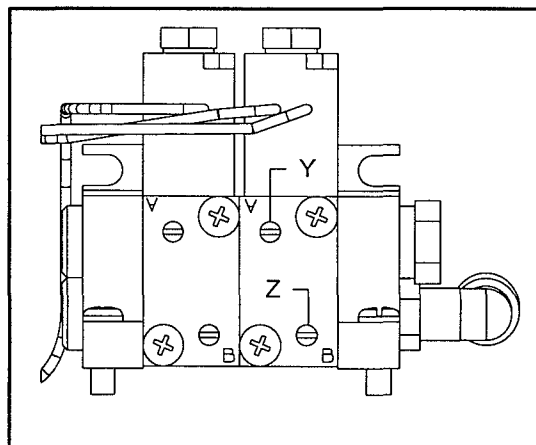

**Fig 7**

## SETTING MICRO SWITCH FOR TRIMMER MECHANISM

The micro switch prevents the motor from running when the thread trimmer mechanism is not in the extreme right position.

Move the thread trimmer mechanism to its extreme right (end) position.

Loosen screw (A).

Adjust micro switch (B) so there is 1mm (.040") between (C) and (D).(Fig7)

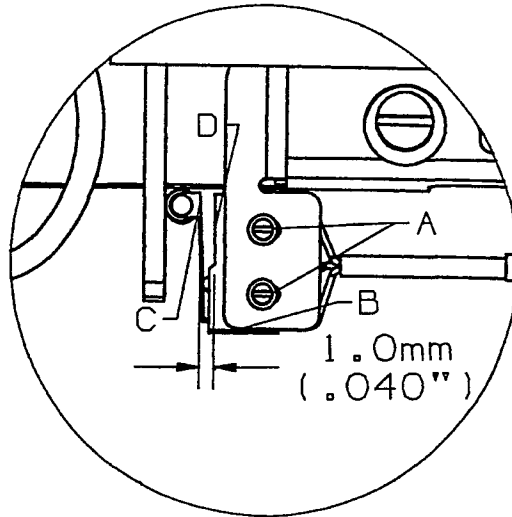
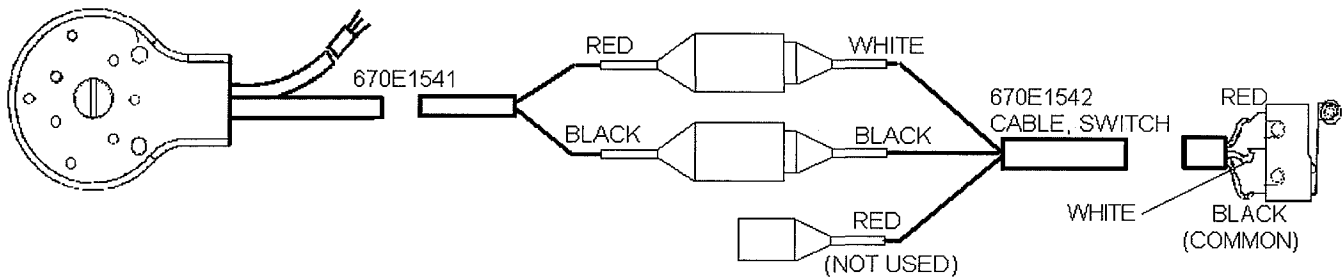

Fig 8

## MICRO SAFETY SWITCH CONNECTION

### JUKI SC380 MOTOR



### Parameter S6L set at "Hi" (Default)

**NOTE:** For motors not listed, refer to the motor manufacturers manual for the proper connection of the micro safety switch. The red and black wires of cable 670E1541 are connected to pins #4 and #6 of the 10 pin hirschmann plug, this is for the motor listed, others may be different.



## NEEDLE THREAD WIPER

Bracket installed at 90 angle to needles.

Wiper hook (A) must deflect needle threads to operator on downstroke, (Fig9). Point (D) of the wiper hook must pass the center of left needle by 3.2mm(1/8").(fig10)

On return, wiper hook (A) must catch all needle threads (Fig11) and draw them into leaf spring (B) to be clamped.

Wiper hook (A) and leaf spring (B) should be flush at point (C) when at rest position.

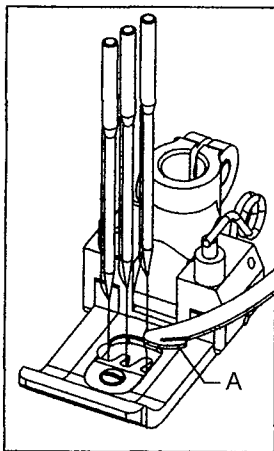
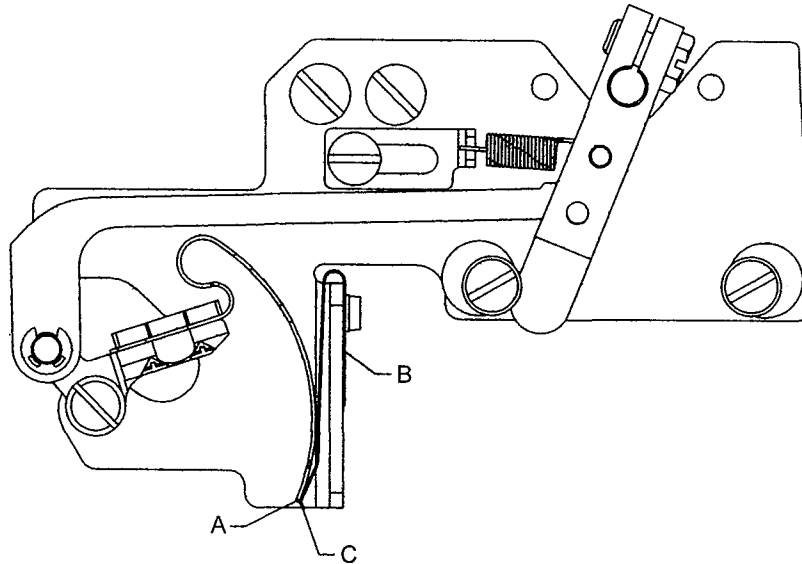

Fig 9

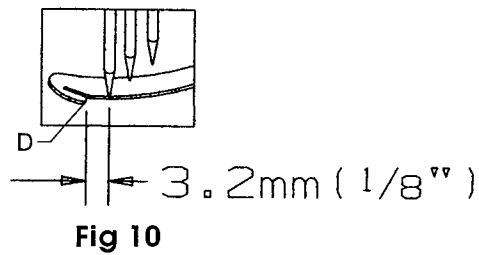

Fig 10

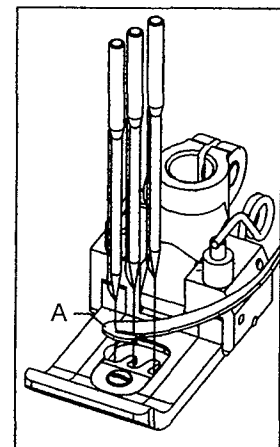

Fig 11

## ADJUSTING THREAD WIPER

Disconnect power supply for thread wiper.

Loosen screws (D). Move wiper (A) left or right as necessary.

Retighten screws (D).

Operate wiper manually to check adjustment.

Loosen screw (E), move leaf spring (B) flush with wiper (A) at point (C).

Retighten screw (E).

Reconnect power supply.

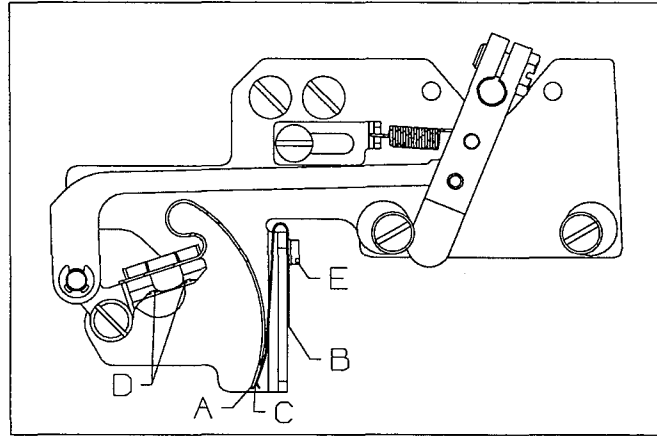

**Fig 12**

To lengthen travel past left needle.

Disconnect power supply to thread wiper.

Loosen stop screw (A) and rotate eccentric (B) so high lobe is further to left. Retighten stop screw (A).

To move wiper higher in leaf spring.

Loosen screw (C) and rotate eccentric (D) so high lobe is further to the right. Tighten stop screw (C).

Reconnect power supply.

NOTE: Recheck leaf spring setting to wiper.

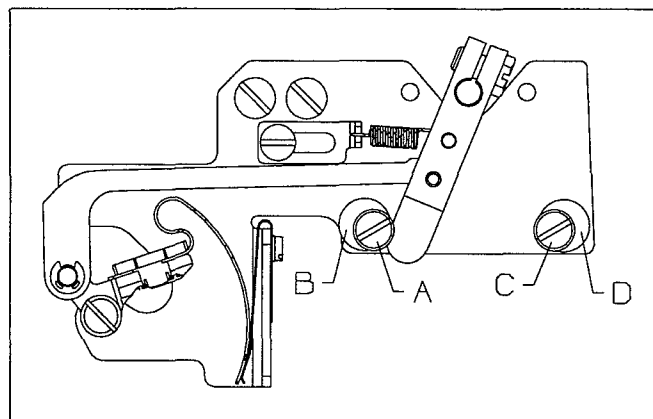

**Fig 13**

## COVER THREAD TRIMMER

The following adjustments are made with the needles at top dead center.

Set the pressure of knife (A) to the minimum and still cut the spreader thread.(Fig14)

The trimmer activates so the hook of the knife (A) picks up the spreader thread from the underside where the thread goes from the spreader to the switch.(Fig14)

The bottom of the moving knife should be 1.5mm - 2mm(.060" - .080") above the presser foot when the moving knife is extended.(Fig14).

The clearance of the knife tip (A) should be 0.4mm to 0.8mm(.016" - .032") from the left needle (B) and 0.2mm to 0.4mm(.008" - .016") from the spreader (C). the angle should be set to pick up the spreader thread.(Fig15, Fig16)

Tighten the set screw (D) in the assembly holder and also tighten the set screw (E) in the collar with the collar against the holder.(Fig17)

The collar screw should not be removed once the trimmer is adjusted. The collar will hold the adjusted position of the trimmer if it should be removed from the holder.

NOTE: Adjust the presser foot delay so it does not interfere with the trimmer.

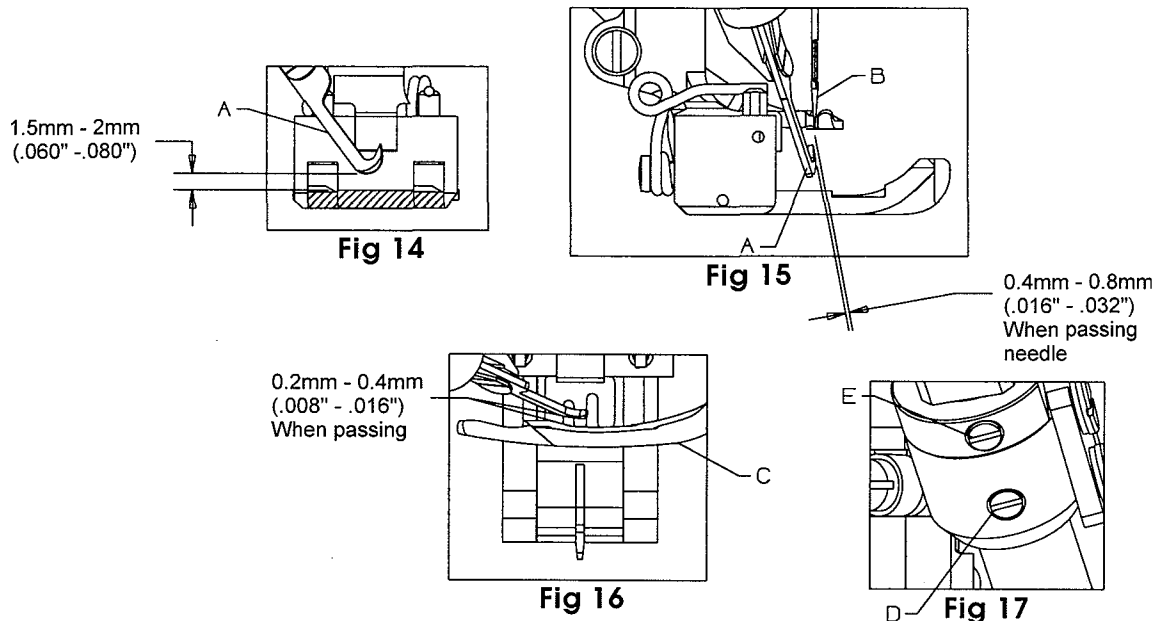

## NEEDLE THREAD BLOWER ASSEMBLY

Needle threads must be blown out from under a raised presser foot after material has been removed.

### AIR FLOW CONTROL

1. Turn needle valve (A) clockwise to decrease air flow.
2. Turn needle valve (A) counterclockwise to increase air flow.

NOTE: For proper air pressure refer to pages 56 - 63

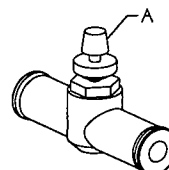
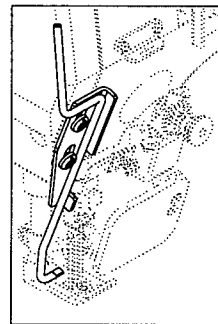

THREAD TRIMMER AND WIPER DEVICE TROUBLE SHOOTING

**1.Klipp-it® thread trimmer device**

Trouble	Cause	Solution	Ref. Page
1) Not clamping looper thread	Position incorrect lower knife to spring	Adjust upper knife overlap to 0.5mm	P.13 (L, M)
	Spring alignment wrong	Adjust correctly	P.13
	Tension on clamping spring to light	Adjust tension screw.	P.13 (H1)
	Worn out tension spring	Change new spring	P.13 (N)
	Pull-off eyelet threading wrong	Correct threading	P.9
	Stroke over 18mm	Reset stroke to 18mm	P.10
2) Looper thread wrap up on take-up cam	Same as1), missing looper clamp	Adjust looper clamping	P.13
3) Not trimming needle thread or looper thread	Upper knife edge not sharp, worn out cutting edge.	Change new parts	P.13
	Knife stroke too short	Reset 18mm stroke of drive	P.10,11
	Incorrect return upper knife position	Check and adjust home position to 0.5mm overlap	P.11,13
	Incorrect needle upper position	Adjust synchronizer position	
	Tension on clamping spring to light	Adjust tension screw.	P.13 (H1)
	Worn out tension spring	Change new spring	P.13 (N)
4) Needle thread remain under the throat plate after trimming.	Incorrect lower knife position over looper and twice trim needle thread in same time	Adjust eccentric	P.14 (U)
5) Nicks on lower knife	Hitting needles or looper	Check motor setting and Timing	
		Adjust guide up or down to correct position	P.14 (X)
6) Does not start thread trimmer when pedal heel back	Parts bind or incorrect air pressure	Check parts or air pressure	
	Connector error or wire broke	Check wiring from Klipp-it drive	
7) Motor does not run	Does not work Micro switch	Adjust setting	P.16
	Broke Micro switch	Change parts	P.16
	Bad power switch or fuse	Check power switch and fuse	
	Micro switch connector wiring wrong	Set correctly	P.16
	Parameter setting wrong	Check motor control box program	

THREAD TRIMMER AND WIPER DEVICE TROUBLE SHOOTING (CONT)

**2. Thread Wiper device**

Trouble	Cause	Solution	Ref. Page
1) Missing needle thread	Incorrect wiper position or stroke	Re-adjust wiper or stroke	P.17
2) Not clamping needle thread	Wiper hook return position incorrect	Adjust stop eccentric	P.18 (B,D)
	Spring does not clamp thread	Adjust leaf spring	P18 (B)

**3. Cover thread trimmer device**

Trouble	Cause	Solution	Ref. Page
1) Not trimming spreader thread	Upper knife edge not sharp, worn out cutting edge.	Change new parts	
	Tension on clamping spring to light	Adjust tension screw.	P.19
	Worn out tension spring	Change new spring	P.19
2) Missing spreader thread	Moving knife set incorrect	Adjust trimmer position	P.19
3) Does not work	No air pressure	Check air pressure or valve	
	Incorrect wiring	Check wiring	

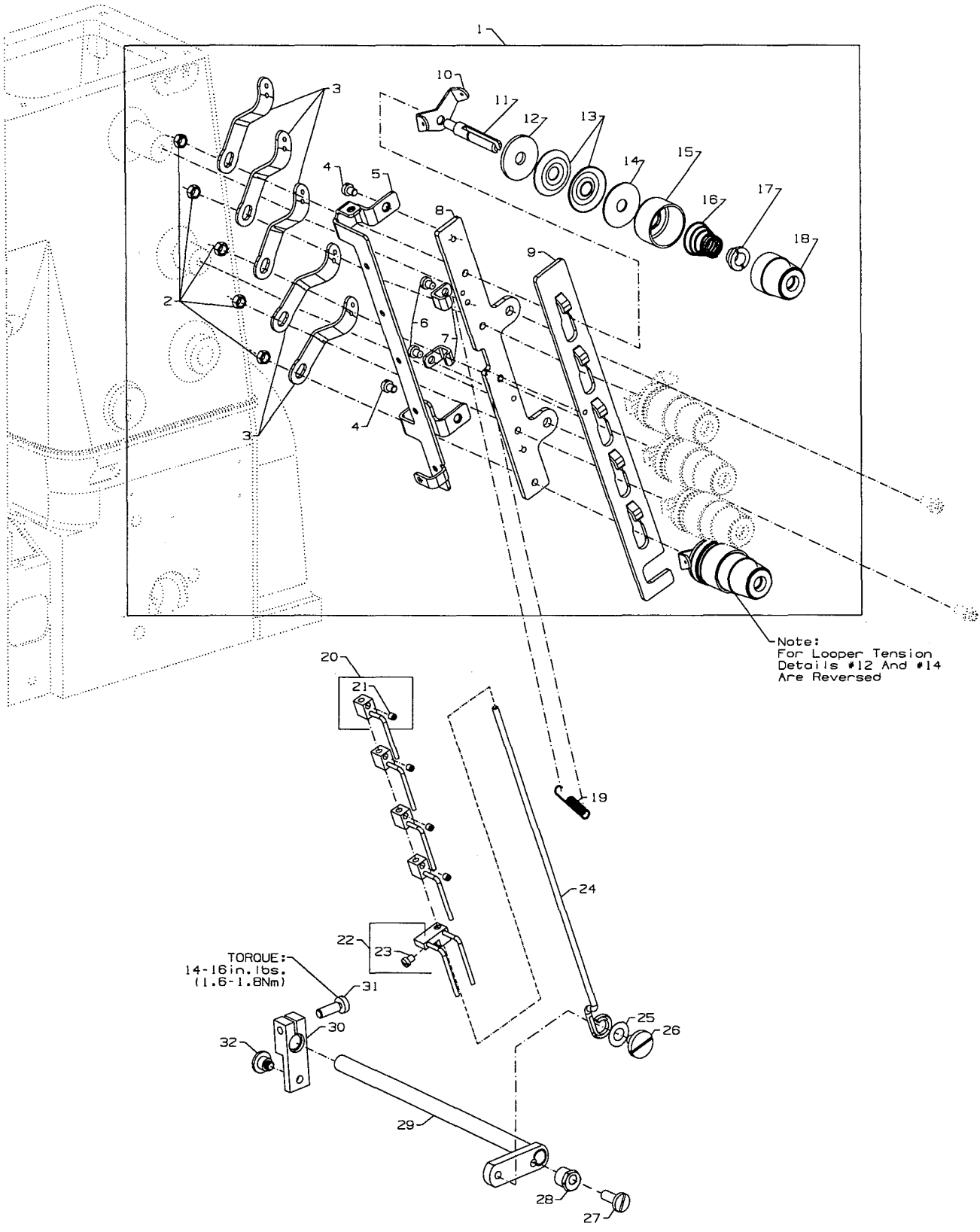

## THREAD TENSION

1.	29477NL	5 Thread Tension Assembly .....	1
2.	NS6110420SP	Nut .....	5
3.	57865	Lead-in Thread Guide .....	5
4.	SS7090520SP	Screw .....	2
5.	50392AP	Thread Guide .....	1
6.	SS7090520SP	Screw .....	2
7.	50392AV	Guide, for tension disc separator .....	2
8.	50392X	Tension Bracket .....	1
9.	50392AR	Tension Disc Separator .....	1
10.	57892K	Thread Tension Eyelet .....	5
11.	56392G	Tension Post .....	5
12.	666-330	Tension Disc Felt .....	5
13.	B3126012000	Tension Disc .....	10
14.	B3120352000	Tension Disc Felt .....	5
15.	56392H	Spring Shield .....	5
16.	B3103804000	Spring, for spreader (blue) .....	1
-	B3101804000	Spring, for needle (red) .....	3
-	B3121804000	Spring, for looper (plain) .....	1
17.	B3112704000	Ferrule, for tension spring .....	5
18.	56392M	Knob, for spreader (blue) .....	1
-	56392L	Knob, for needle (red) .....	3
-	50392R	Knob, for looper (plain) .....	1
19.	96711	Extension Spring .....	1
20.	50358Y	Thread Pull-off Hook .....	4
21.	28C	Screw .....	4
22.	A9858	Thread Pull-off Hook .....	1
23.	77A	Screw .....	1
24.	50392AS	Puller Rod, for thread puller .....	1
25.	50374A	Washer .....	1
26.	99296	Shoulder Screw .....	1
27.	22757	Screw .....	1
28.	G51346KA	Tension Release Eccentric .....	1
29.	50392AN	Tension Release Assembly .....	1
30.	99620	Tension Release Lever .....	1
31.	22596	Screw .....	1
32.	22735	Screw .....	1

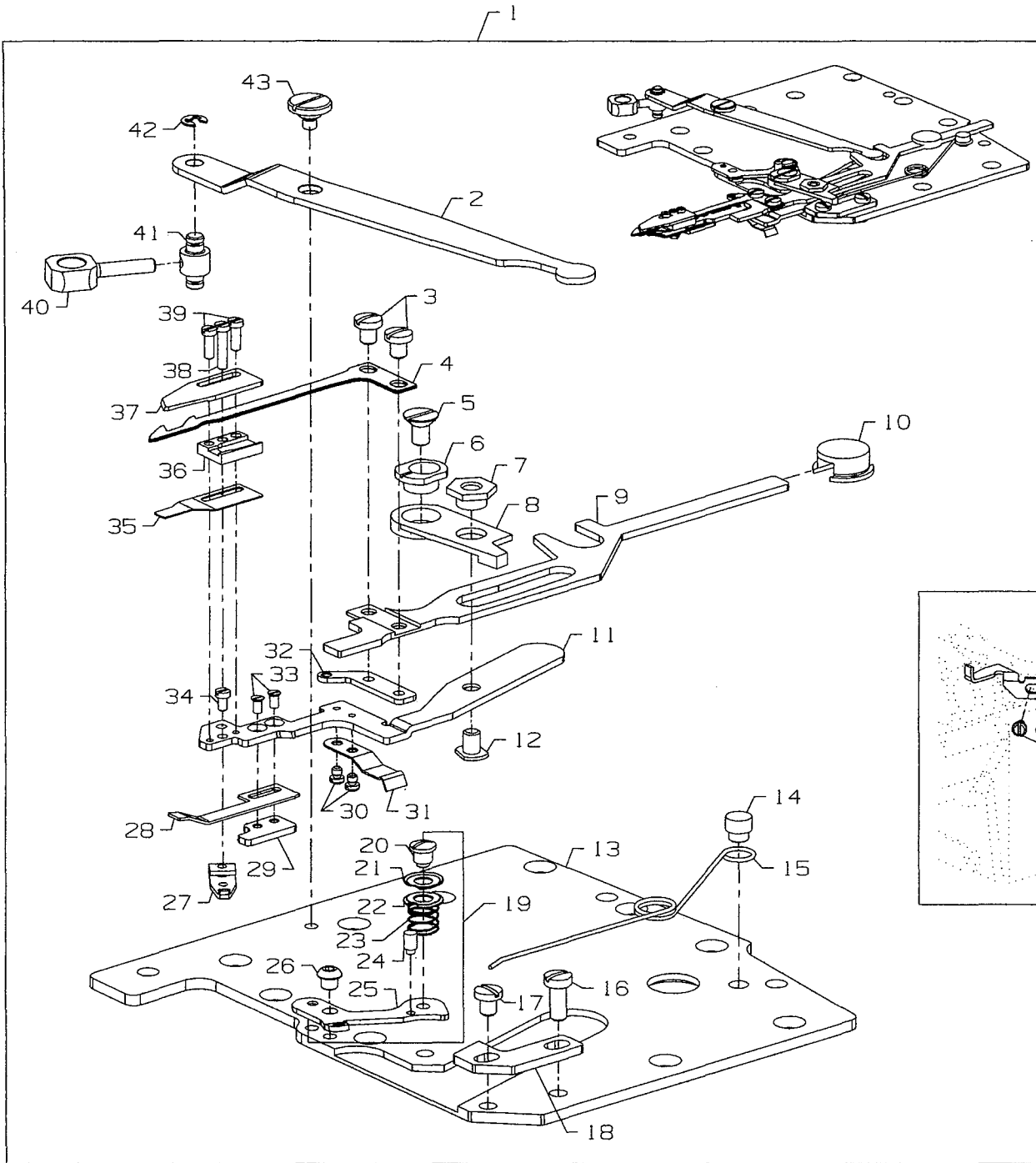



## KLIPP-IT® THREAD TRIMMER ASSEMBLY

Ref. No.	Part No.	Description	Amt. Req.
1.	29480AYH	Klipp-it® Thread Trimmer Assembly .....	1
2.	34763P	Lever .....	1
3.	18-1453	Screw .....	2
4.	34749P	Lower Knife .....	1
5.	18C1481	Screw .....	1
6.	34768A	Eccentric Guide .....	1
7.	34768C	Guide Washer .....	1
8.	34750R	Lever .....	1
9.	34750T	Lower Knife Holder .....	1
10.	34750U	Guide .....	1
11.	34750SA	Upper Knife Holder .....	1
12.	18-1472	Screw .....	1
13.	34382AC	Oil Reserve Cover .....	1
14.	34751MS	Pin .....	1
15.	50332AD	Spring .....	1
16.	22585	Screw .....	1
17.	18-1449	Screw .....	1
18.	50337AX	Stop .....	1
19.	29480AYJ	Looper Thread Nipper Assembly .....	1
20.	50357AW	Nipper Plate Screw .....	1
21.	50357AX	Nipper Plate .....	1
22.	50357AT	Nipper Plate .....	1
23.	50357AU	Nipper Spring .....	1
24.	50357AV	Nipper Guard Post .....	1
25.	50366L	Nipper Plate Eyelet .....	1
26.	SM5030355SN	Screw .....	1
27.	34751MT	Tension Lever .....	1
28.	34773D	Leaf Spring .....	1
29.	34769B	Threaded Plate .....	1
30.	SM6020250TP	Screw .....	2
31.	34773E	Leaf Spring .....	1
32.	50368AE	Looper Thread Pull-off Eyelet .....	1
33.	SM1020450TP	Screw .....	2
34.	18-1473	Screw .....	1
35.	34773F	Leaf Spring .....	1
36.	34750P	Lower Knife Guide .....	1
37.	34770M	Upper Knife .....	1
38.	18-1474	Screw .....	1
39.	SM6020600TP	Screw .....	2
40.	34752M	Driving Link .....	1
41.	34752N	Carrier Bolt .....	1
42.	RE025000KO	E-Ring .....	1
43.	SD0600176SP	Screw .....	1
44.	34794A	Guide .....	1
45.	90	Screw, for guide .....	2

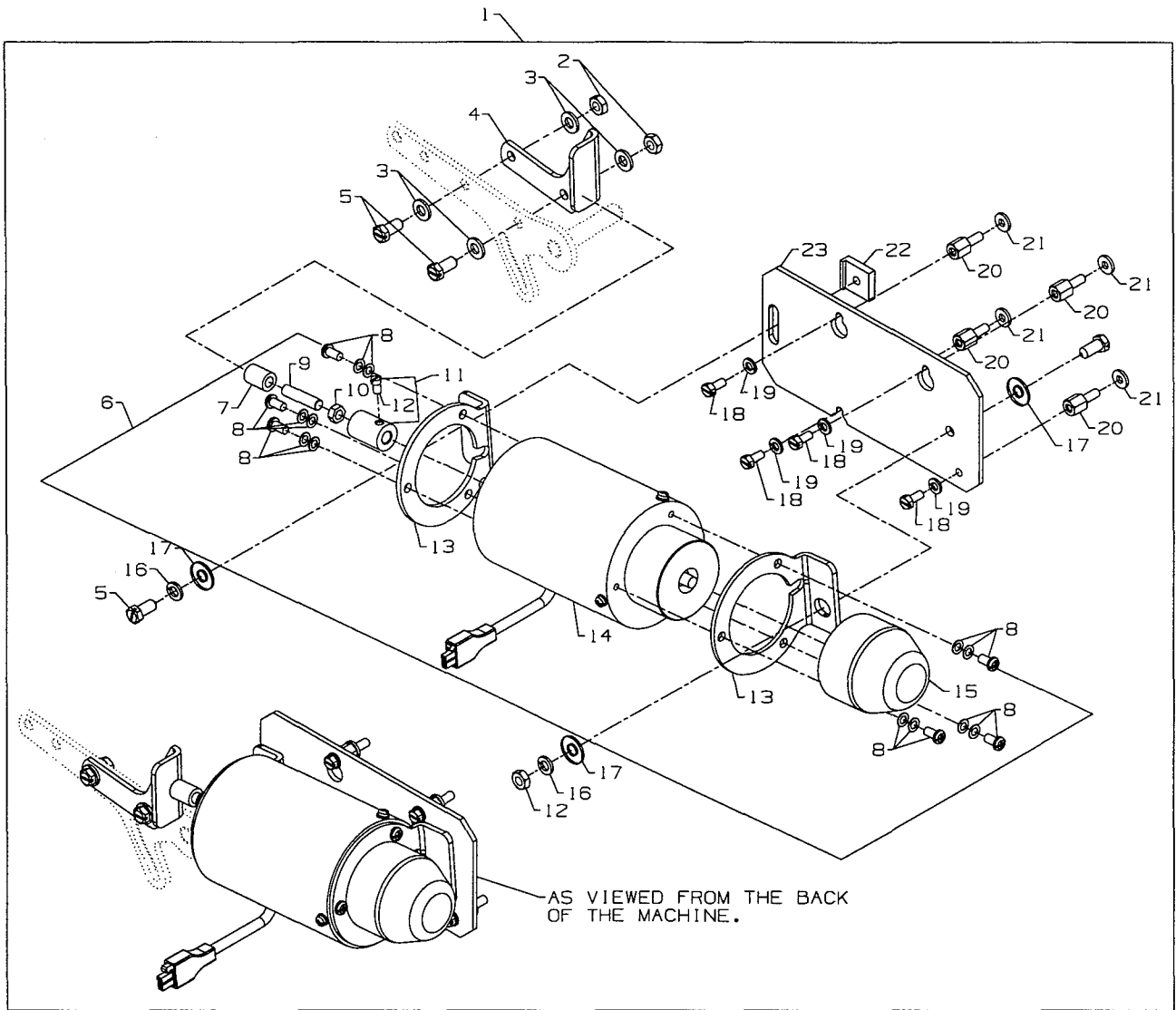

## ELECTRIC PRESSER FOOT LIFTER ASSEMBLY

Ref. No.	Part No.	Description	Amt. Req.
1.	29921D	Electric Drive Assembly .....	1
2.	NS6150430SP	Nut .....	3
3.	95951	Washer .....	4
4.	50367H	Lifter .....	1
5.	SS9151420TP	Hex Screw .....	4
6.	670K29	Solenoid Assembly .....	1
7.	92855A	Cap .....	1
8.	SS4051281SE	Screw .....	6
9.	50395N	Stud .....	1
10.	NS6660430SP	Nut .....	1
11.	50333B	Coupling .....	1
12.	SS6110710TP	Screw .....	1
13.	GAK33034000	Bracket .....	2
14.	GAK8403000A	Solenoid .....	1
15.	GAK3303600A	Cap .....	1
16.	WS0631510KP	Lock Washer .....	2
17.	53636C	Washer .....	3
18.	SS9111010SP	Hex Screw .....	4
19.	WS0510002KP	Lock Washer .....	4
20.	50395P	Stand-Off .....	4
21.	35032H	Washer .....	4
22.	50395R	Clamp Plate .....	1
23.	50383S	Base Plate .....	1

UT COMPONENT DEVICE KEY	
UT DEVICE	COMPONENT USED ON DEVICE
UT1	●
UT2	●
UT3	
UT4	
UT5	
UT6	●

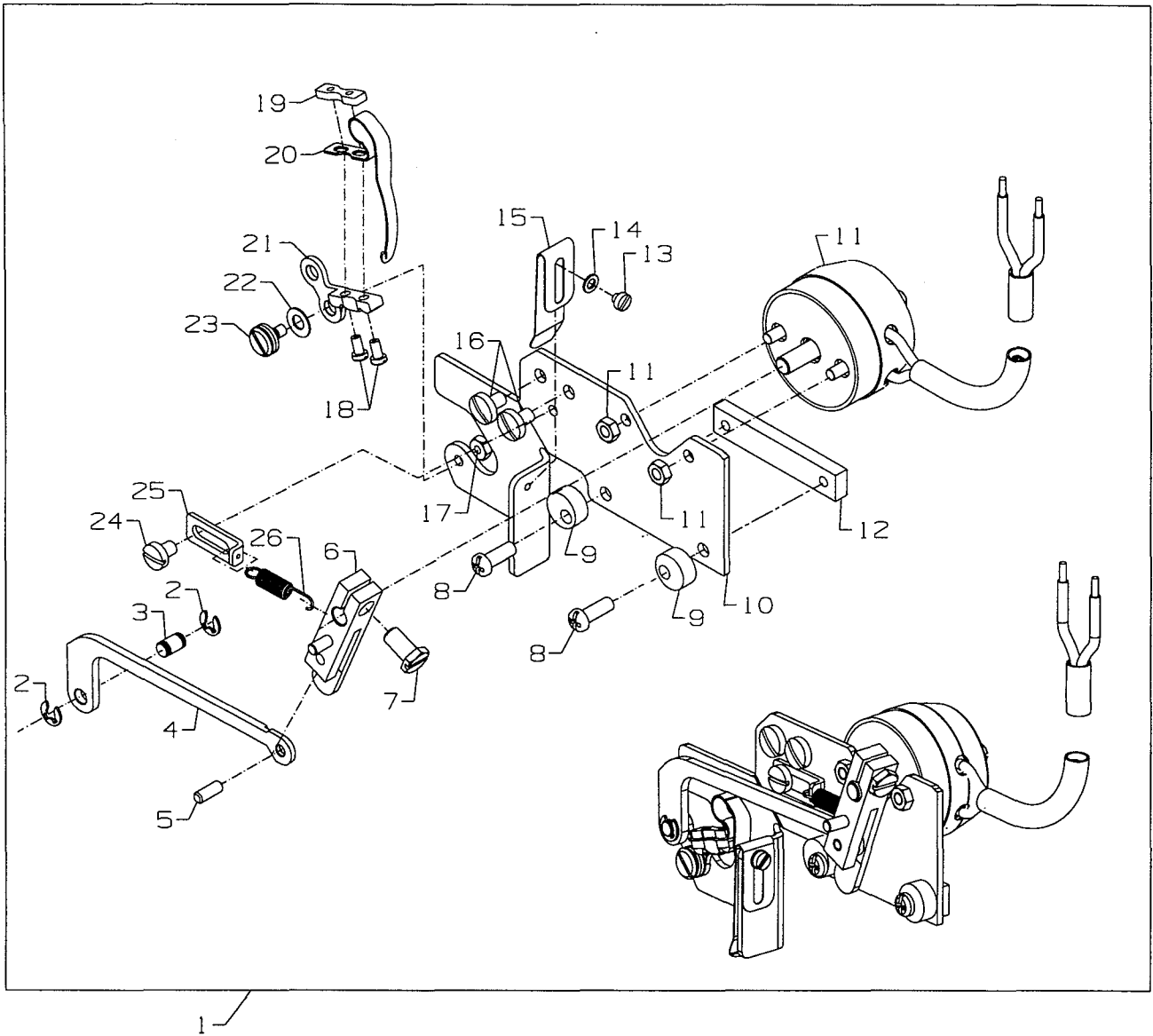

From the library of: Diamond Needle Corp

## ELECTRIC THREAD WIPER ASSEMBLY

Ref. No.	Part No.	Description	Amt. Req.
1.	29906M	Electric Thread Drive Assembly .....	1
2.	96280	Retaining Ring .....	2
3.	99591DN	Pin .....	1
4.	99545G	Push Rod .....	1
5.	PH0300083U0	Pin .....	1
6.	99646J	Lever .....	1
7.	SS9120910TP	Screw .....	1
8.	SS4091015SP	Screw .....	2
9.	50363BF	Stop Eccentric .....	2
10.	99650E	Wiper Bracket .....	1
11.	670K15	Electric Solenoid Rotary .....	1
12.	99545H	Nut Plate .....	1
13.	SS6060210SP	Screw .....	1
14.	96150	Washer .....	1
15.	99697AA	Leaf Spring .....	1
16.	SS7090610SP	Screw .....	2
17.	51250C	Hex Nut .....	1
18.	SS6060510TP	Screw .....	2
19.	50362B	Plate .....	1
20.	99653B	Wiper Hook .....	1
21.	99657E	Lever .....	1
22.	96161	Washer .....	1
23.	99358	Shoulder Screw .....	1
24.	SS7090510SP	Screw .....	1
25.	99591DP	Bracket .....	1
26.	50332AB	Extension Spring .....	1

UT COMPONENT DEVICE KEY	
UT DEVICE	COMPONENT USED ON DEVICE
UT1	●
UT2	
UT3	
UT4	
UT5	
UT6	

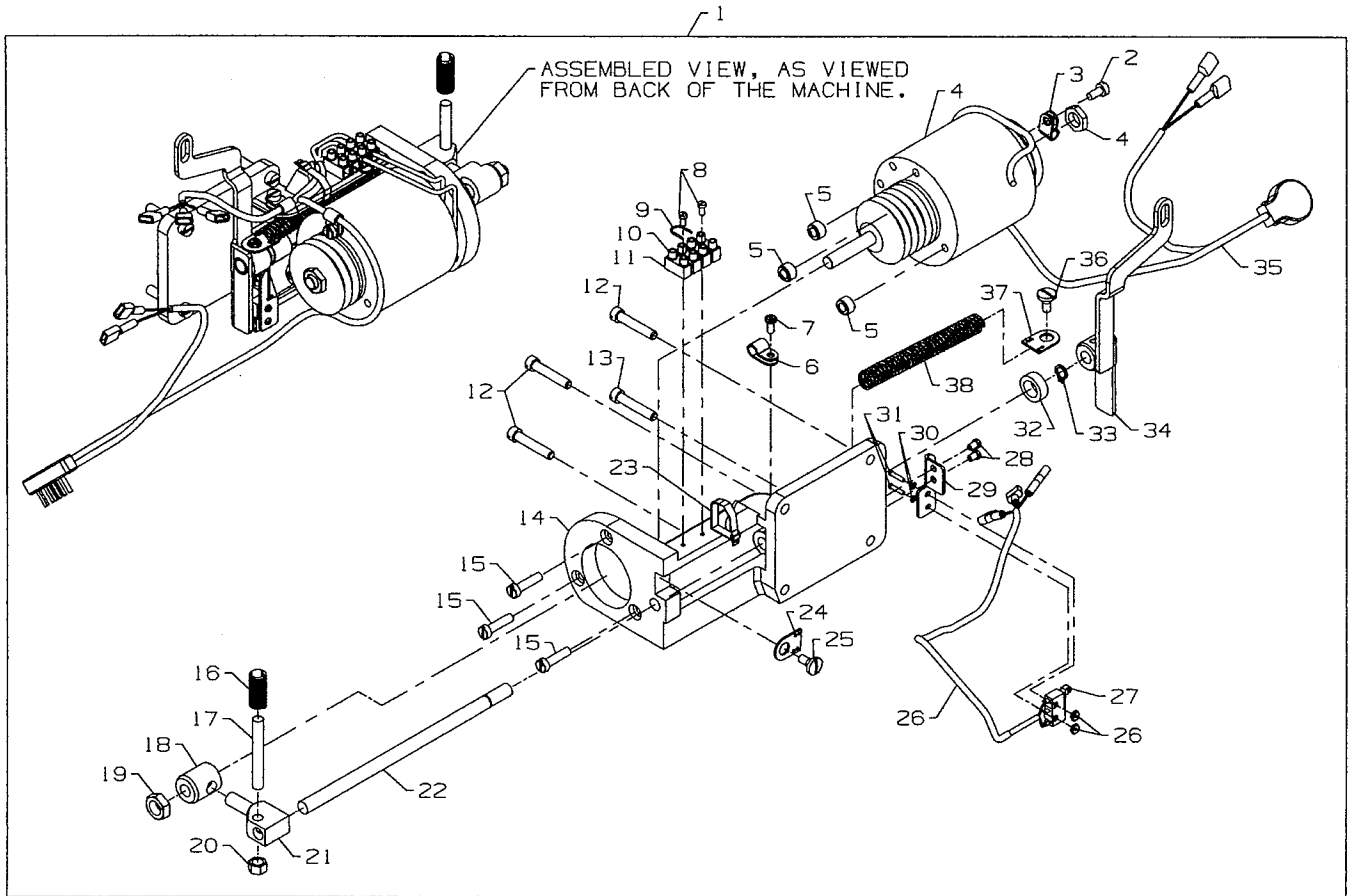

## ELECTRIC DRIVE ASSEMBLY

Ref. No.	Part No.	Description	Amt. Req.
1.	670K28	Electric Drive Assembly .....	1
2.	95169	Screw .....	1
3.	670E1508	Cable Clamp .....	1
4.	998-306B	Solenoid .....	1
5.	99617A	Bushing .....	3
6.	998-358E	Hose Clamp .....	2
7.	SS611101OSP	Screw .....	1
8.	95179K	Screw .....	2
9.	1318001	Wire .....	1
10.	670E1302	Terminal Block .....	1
11.	998-297A	Cable End Plate .....	2
12.	22852A	Screw .....	3
13.	22517A	Screw .....	1
14.	G52882KW	Mounting Bracket .....	1
15.	95177	Screw .....	3
16.	51292F2	Spring .....	1
17.	99619	Clamping Screw .....	1
18.	99616	Driving Connection .....	1
19.	95251	Nut .....	1
20.	55235E	Nut .....	1
21.	99614D	Cross Head .....	1
22.	99613D	Shaft .....	1
23.	RM2871B	Wire Tie .....	2
24.	80696RA	Spring Eyelet .....	1
25.	14076	Screw .....	1
26.	60078Z	Nut .....	1
27.	670E1542	Cable and Switch Assembly .....	1
28.	22513B	Screw .....	2
29.	50383BK	Bracket .....	1
30.	96151	Washer .....	2
31.	22738D	Screw .....	2
32.	99615	Washer .....	1
33.	96261	Retaining Ring .....	1
34.	50373DG	Lever .....	1
35.	670E1541	Cable .....	1
36.	22569B	Screw .....	1
37.	80696RA	Spring Eyelet .....	1
38.	96721	Spring .....	1

UT COMPONENT DEVICE KEY	
UT DEVICE	COMPONENT USED ON DEVICE
UT1	●
UT2	●
UT3	
UT4	
UT5	
UT6	●

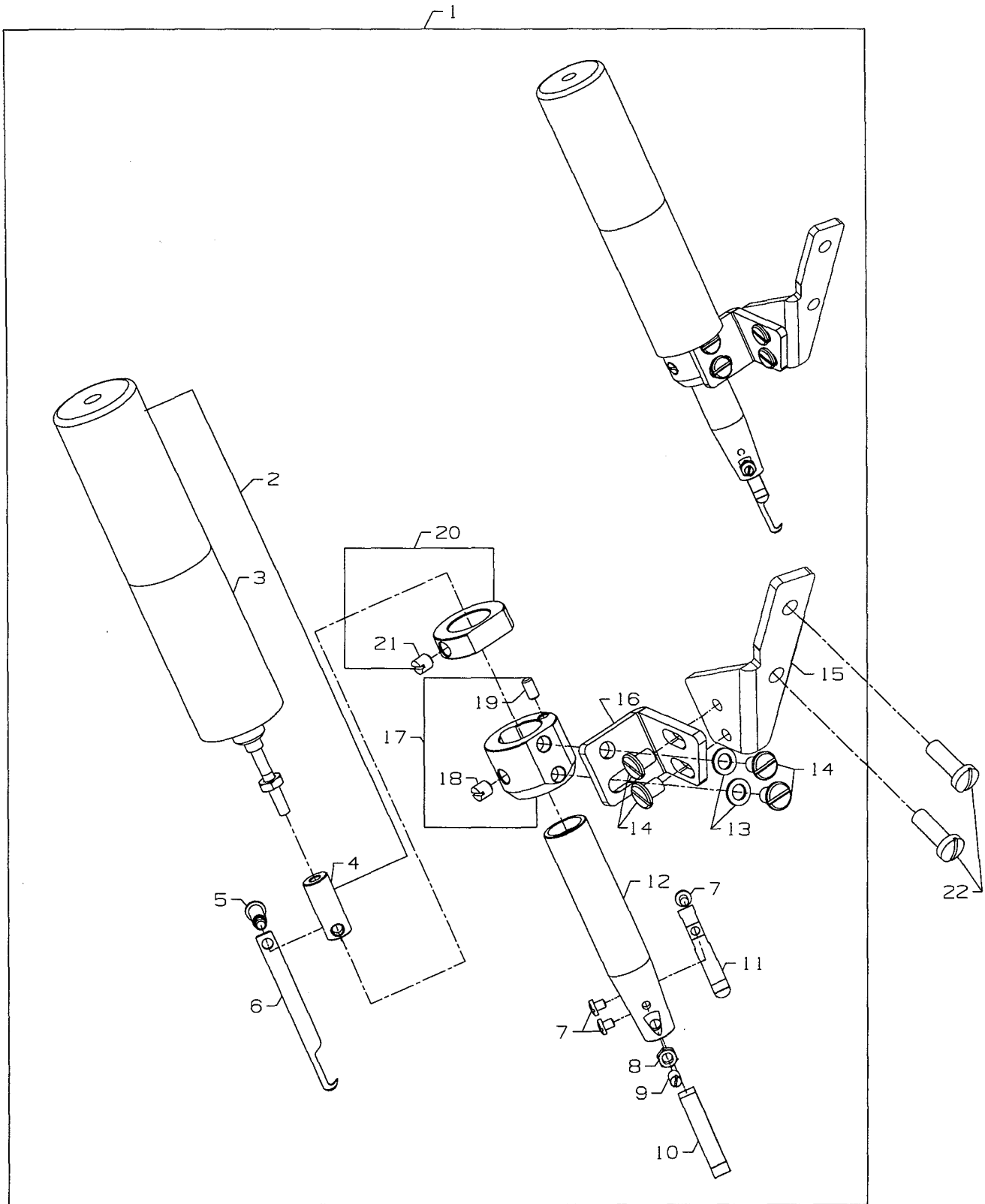



## ELECTRIC SPREADER THREAD TRIMMER ASSEMBLY

Ref. No.	Part No.	Description	Amt. Req.
1.	29980LE	Spreader Thread Trimmer Assembly, Electric .....	1
2.	29105BR	Knife Holder Assembly .....	1
3.	670K85	Solenoid .....	1
4.	50372D	Moving Knife Holder .....	1
5.	22731	Screw .....	1
6.	50370H	Moving Knife .....	1
7.	SS706310SP	Screw .....	2
8.	NS6080210SP	Nut .....	1
9.	SS8080610SP	Screw .....	1
10.	50349F	Lower Knife .....	1
11.	50332AG	Spring .....	1
12.	50372C	Knife Holder .....	1
13.	WPO450846SP	Washer .....	2
14.	SS6110610TP	Screw .....	4
15.	50383AT	Bracket .....	1
16.	50383AS	Bracket .....	1
17.	50333L	Collar Guide .....	1
18.	SS8110520TP	Screw .....	1
19.	PH0300062C0	Pin .....	1
20.	50333K	Collar .....	1
21.	SS8110520TP	Screw .....	1
22.	SS4121915SP	Mounting Screws .....	2

UT COMPONENT DEVICE KEY	
UT DEVICE	COMPONENT USED ON DEVICE
UT1	
UT2	●
UT3	
UT4	
UT5	
UT6	

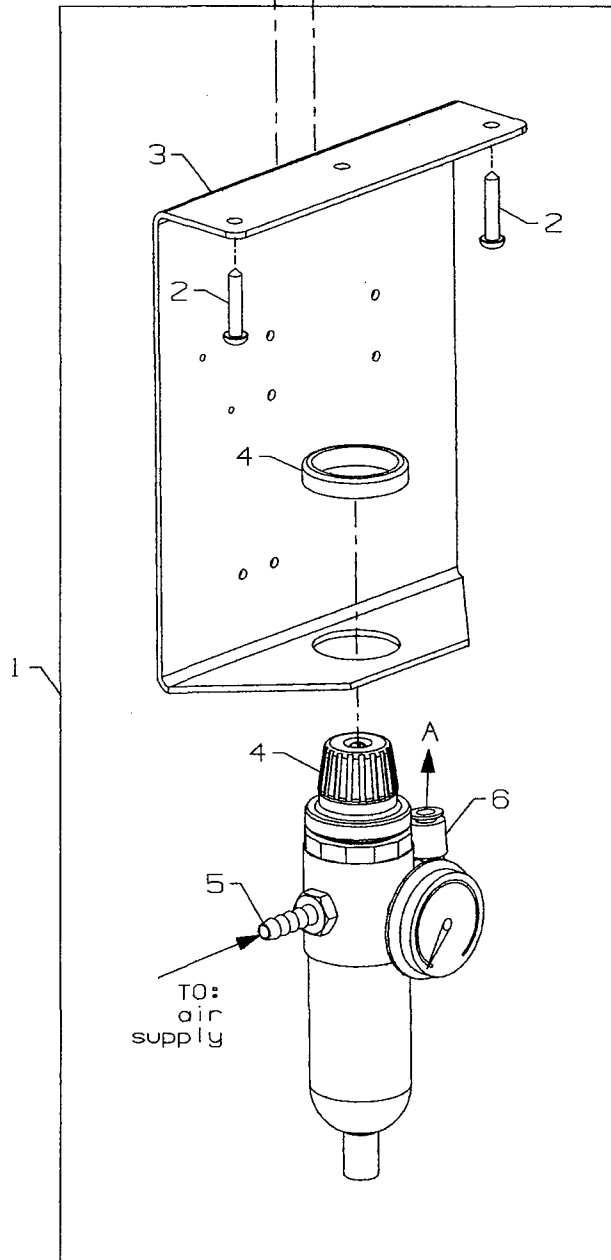
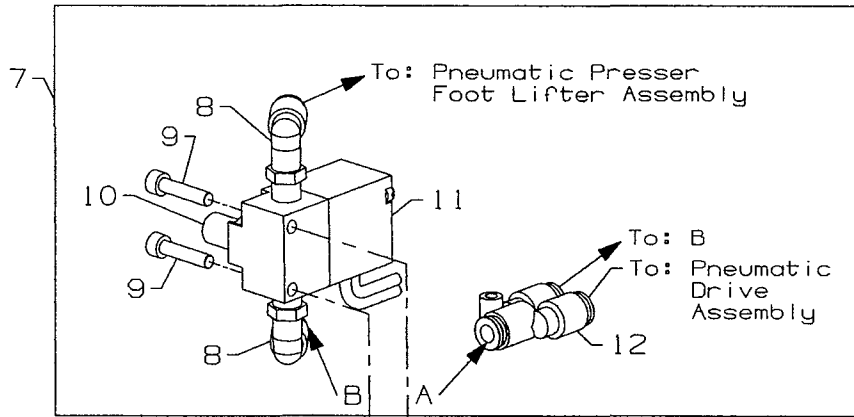

## PNEUMATIC CONTROL

Ref. No.	Part No.	Description	Amt. Req.
1.	29480ASU	Pneumatic Control Kit .....	1
2.	90561K	Wood Screw .....	2
3.	99683CP	Mounting Bracket .....	1
4.	671D42	Filter/ Regulator Assembly .....	1
5.	671F88	Barb Fitting .....	1
6.	671F81A	Elbow Fitting - 1/4" x 1/2" NPT .....	1
-	671B182	Air Tubing - 6mm O.D. x 1m (not shown) .....	1
7.	29480AWU	Presser Foot Lifter Kit .....	1
8.	671F81C	Elbow Fitting - 1/4" x 1/8" NPT .....	2
9.	95415	Screw - 4mm .....	2
10.	660-403	Muffler .....	1
11.	671-50	Valve .....	1
12.	671F86B	Splitter .....	1
-	HK034610020	Connection Plug (2 Pins, not shown) .....	1
-	HK03464000B	Terminal Pin (not shown) .....	2
-	671B23	Air Tubing - 1/4" O.D. x 1mm (not shown) .....	1

UT COMPONENT DEVICE KEY	
UT DEVICE	COMPONENT USED ON DEVICE
UT1	
UT2	
UT3	●
UT4	●
UT5	●
UT6	

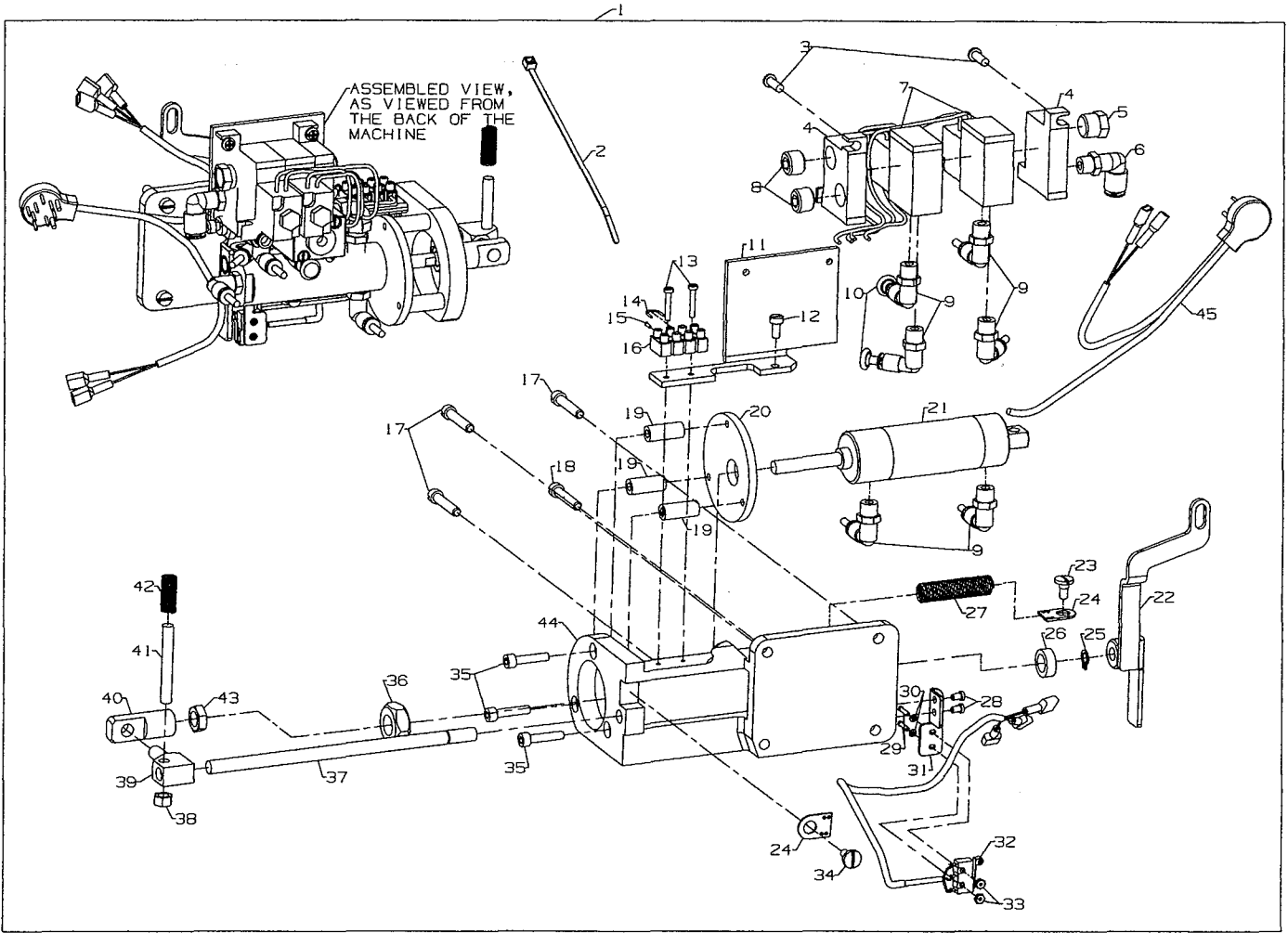

From the library of: Diamond Needle Corp

## PNEUMATIC DRIVE DOUBLE ACTION ASSEMBLY

Ref. No.	Part No.	Description	Amt. Req.
1.	29480ATW	Pneumatic Drive Assembly .....	1
2.	RM2871B	Cable Tie .....	2
3.	SS4121415SP	Screw .....	2
4.	671-104A	Manifold .....	1
5.	660-763	Silencer .....	1
6.	671F81A	Elbow .....	1
7.	671-103B	Mac Valve .....	2
8.	671F87	Plug .....	2
9.	671F82C	Elbow .....	6
10.	670G276	Plug .....	2
11.	50383N	Bracket .....	1
12.	SS6111010SP	Screw .....	1
13.	22894AX	Screw .....	2
14.	1318001	Wire .....	1
15.	998-297A	Cable End Sleeve .....	2
16.	670E1302	Terminal .....	1
17.	22852A	Screw .....	3
18.	22517A	Screw .....	1
19.	99617T	Spacer .....	3
20.	99591DH	Disc .....	1
21.	99694A	Air Cylinder .....	1
22.	50373DG	Lever .....	1
23.	22569B	Screw .....	1
24.	80696RA	Spring Eyelet .....	1
25.	96261	Retaining Ring .....	1
26.	99615	Washer .....	1
27.	96721	Spring .....	1
28.	22513B	Screw .....	2
29.	22738D	Screw .....	2
30.	96151	Washer .....	2
31.	50383BK	Bracket .....	1
32.	670E1542	Cable and Switch .....	1
33.	60078Z	Nut .....	2
34.	14076	Stud .....	1
35.	95411	Screw .....	3
36.	99327	Nut .....	1
37.	99613D	Shaft .....	1
38.	55235E	Nut .....	1
39.	99614D	Cross Head .....	1
40.	99616A	Connector .....	1
41.	99619	Clamping .....	1
42.	51292F2	Spring .....	1
43.	21233FB	Nut .....	1
44.	G52882KW	Support Bracket .....	1
45.	670E1541	Cable .....	1
-	671B182	Tubing (not shown)(1.8m) .....	1
-	6-878-4mm-.65mm	Nylon Black Tubing (not shown) .....	1
-	998-358E	Hose Clamp (not shown) .....	1

UT COMPONENT DEVICE KEY	
UT DEVICE	COMPONENT USED ON DEVICE
UT1	
UT2	
UT3	●
UT4	●
UT5	●
UT6	

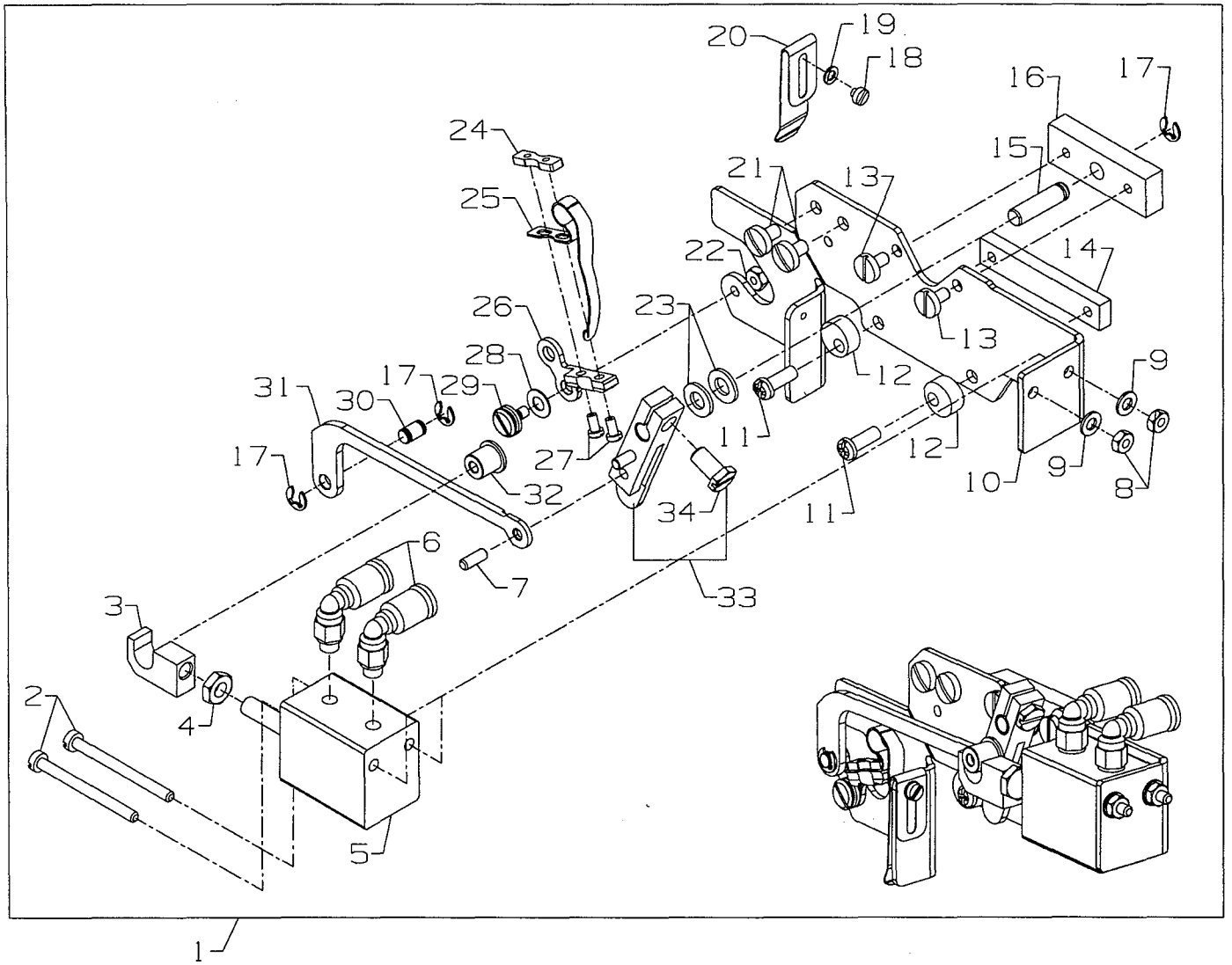

## PNEUMATIC THREAD WIPER ASSEMBLY

Ref. No.	Part No.	Description	Amt. Req.
1.	29906L	Pneumatic Thread Wiper Assembly .....	1
2.	95167CV	Screw .....	2
3.	35086BK	Clevis .....	1
4.	95294	Hex Nut .....	1
5.	999-191H	Pneumatic Cylinder .....	1
6.	999-411M5-4	Pneumatic Fitting .....	2
7.	PH0300083U0	Pin .....	1
8.	95259	Hex Nut .....	2
9.	95956	Washer .....	2
10.	99650D	Wiper Bracket .....	1
11.	SS4091015SP	Screw .....	2
12.	50363BF	Stop Eccentric .....	2
13.	SS6080610TP	Screw .....	2
14.	99545H	Nut Plate .....	1
15.	52336B	Pin .....	1
16.	99545F	Plate .....	1
17.	96280	Retaining Ring .....	3
18.	SS6060210SP	Screw .....	1
19.	96150	Washer .....	1
20.	99697AA	Leaf Spring .....	1
21.	SS7090610SP	Screw .....	2
22.	51250C	Hex Nut .....	1
23.	99652A	Washer .....	2
24.	50362B	Plate .....	1
25.	99653B	Wiper Hook .....	1
26.	99657E	Lever .....	1
27.	SS6060510TP	Screw .....	2
28.	96161	Washer .....	1
29.	99358	Shoulder Screw .....	1
30.	99591DN	Pin .....	1
31.	99545G	Push Rod .....	1
32.	35086BJ	Roller .....	1
33.	99646J	Lever .....	1
34.	SS9120910TP	Screw .....	1
-	6-878-4mm-65mm	Tubing (not shown)(1m) .....	1

UT COMPONENT DEVICE KEY	
UT DEVICE	COMPONENT USED ON DEVICE
UT1	
UT2	
UT3	●
UT4	
UT5	
UT6	

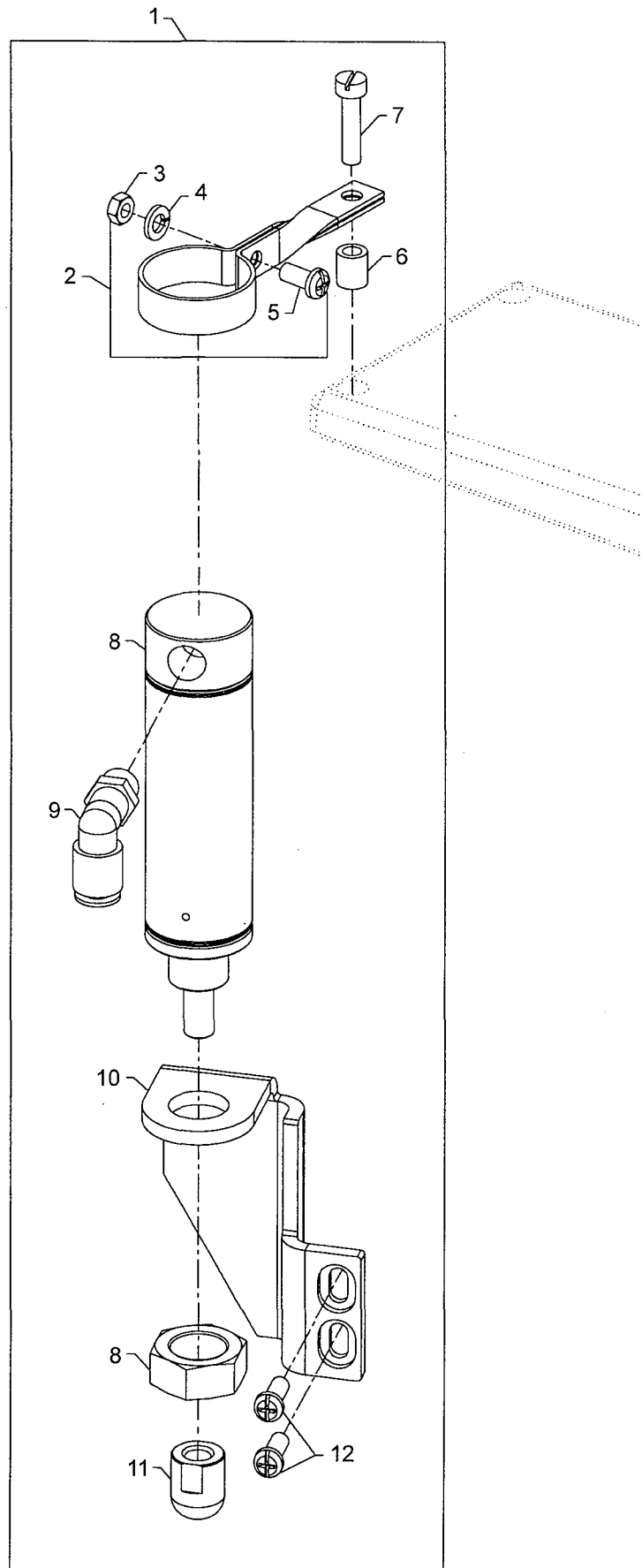



# PRESSER FOOT LIFTER

Ref. No.	Part No.	Description	Amt. Req.
1.	29480AXJ	Presser Foot Lifter Assembly .....	1
2.	50383AR	Cylinder Support Bracket .....	1
3.	NS6120310SP	Nut .....	1
4.	WS0510002KP	Washer .....	1
5.	SS4121015SP	Screw .....	1
6.	50374K	Spacer .....	1
7.	SS6122030SP	Screw .....	1
8.	671A360	Air Cylinder .....	1
9.	671F81C	Fitting .....	1
10.	50383AF	Bracket .....	1
11.	660-1099	Air Cylinder Cap .....	1
12.	SS7121410TP	Screw .....	2
-	671-B23	Tubing (not shown)(1m) .....	1

UT COMPONENT DEVICE KEY	
UT DEVICE	COMPONENT USED ON DEVICE
UT1	
UT2	
UT3	●
UT4	●
UT5	●
UT6	

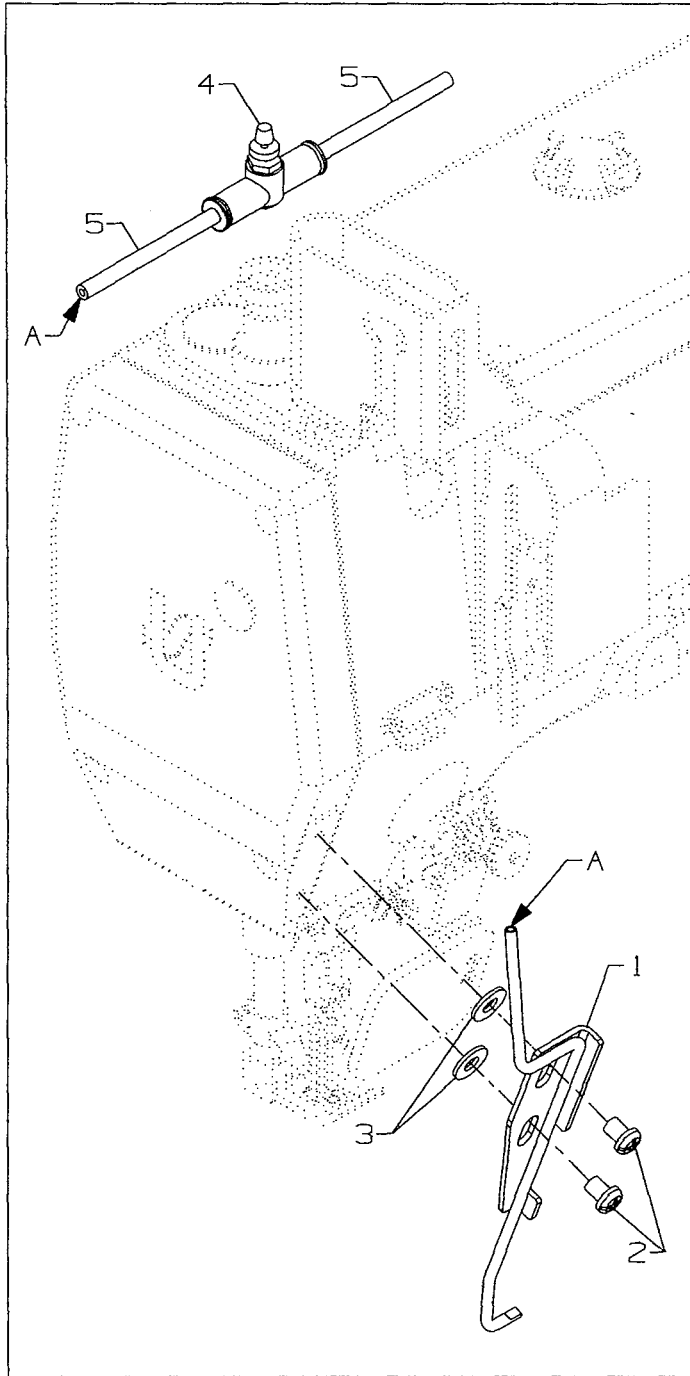

## NEEDLE THREAD BLOWER ASSEMBLY

Ref. No.	Part No.	Description	Amt. Req.
1.	50394AJ	Needle Thread Blower Assembly .....	1
2.	SS4120615SP	Screw, for needle thread blower assembly .....	2
3.	69H	Washer .....	2
4.	671-168	Flow Control Valve .....	1
5.	6-878-4mm-.65mm	Tubing (1m) .....	1

UT COMPONENT DEVICE KEY	
UT DEVICE	COMPONENT USED ON DEVICE
UT1	
UT2	
UT3	
UT4	●
UT5	
UT6	

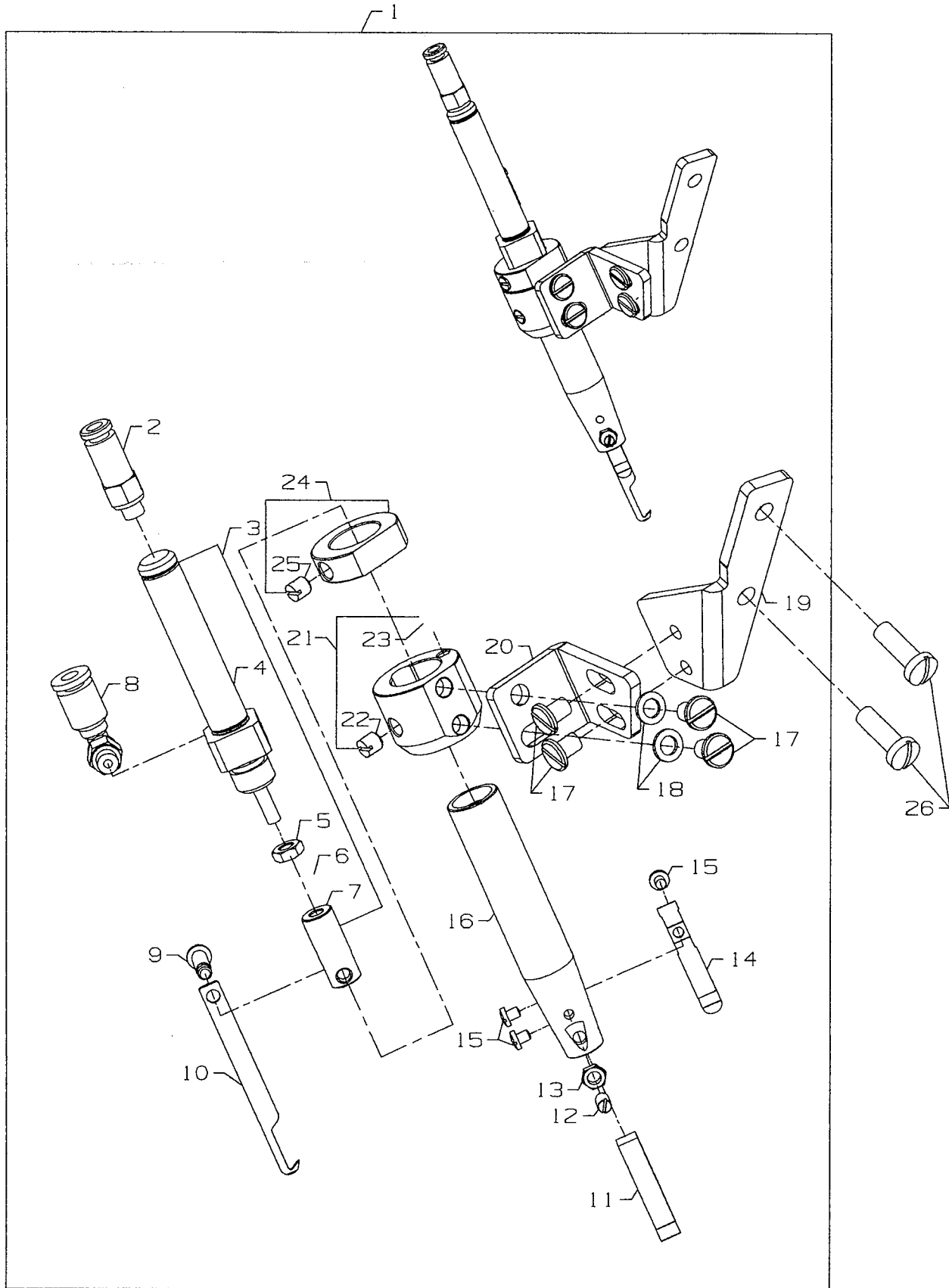

## PNEUMATIC SPREADER THREAD TRIMMER ASSEMBLY

Ref. No.	Part No.	Description	Amt. Req.
1.	29980LD	Pneumatic Spreader Thread Trimmer Assembly .....	1
2.	671F82G	Male Connector .....	1
3.	29105BP	Knife Holder Assmebly .....	1
4.	671A363	Air Cylinder .....	1
5.	660-1105	Nut .....	1
6.	WS0410002KP	Washer .....	1
7.	50372D	Moving Knife Holder .....	1
8.	671F82F	Male Elbow .....	1
9.	22731	Screw .....	1
10.	50370H	Moving Knife .....	1
11.	50349F	Lower Knife .....	1
12.	SS8080610SP	Screw .....	1
13.	NS6080210SP	Nut .....	1
14.	50332AG	Spring .....	1
15.	SS7060310SP	Screw .....	3
16.	50372C	Knife Holder .....	1
17.	SS6110610TP	Screw .....	4
18.	WPO450846SP	Washer .....	2
19.	50383AT	Bracket .....	1
20.	50383AS	Bracket .....	1
21.	50333L	Collagr, guide .....	1
22.	SS8110520TP	Screw .....	1
23.	PH0300062C0	Pin .....	1
24.	50333K	Collar .....	1
25.	SS8110520TP	Screw .....	1
26.	SS4120915SP	Mounting Screws .....	2
-	6-878-4mm-.65mm Tubing (not shown)(1 m) .....		1

UT COMPONENT DEVICE KEY	
UT DEVICE	COMPONENT USED ON DEVICE
UT1	
UT2	
UT3	
UT4	
UT5	●
UT6	

## STITCH CONDENSING ADJUSTMENTS



**TURN OFF MAIN POWER SWITCH BEFORE ADJUSTING! WHEN USING CLUTCH MOTORS WITHOUT ACTUATION LOCK WAIT UNTIL THE MOTOR HAS COMPLETELY STOPPED AND AIR PRESSURE TURNED OFF.**

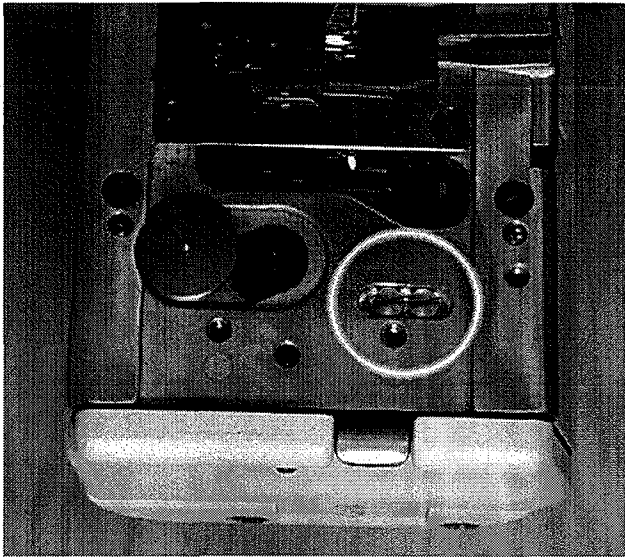

With the air turned off, 50329S air cylinder assembly should be in the center of it's adjusting slot.

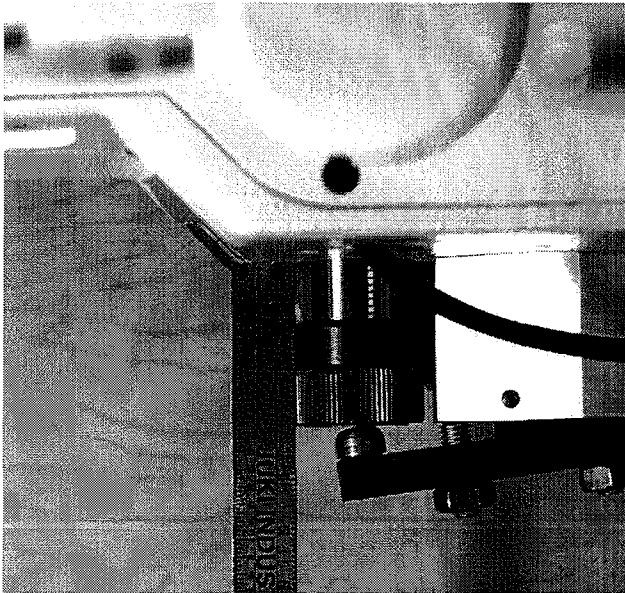

50337AP knob should be turned out so it is 11mm from the hinge plate. This is only a preliminary setting when first setting up the stitch condensing device.

**CAUTION!:** If turned out past 11mm it is possible for linkage in the machine to be disengaged, requiring disassembly of the bottom pan to reengage differential feed drive parts.

## STITCH CONDENSING ADJUSTMENTS

Set the right toggle screw 22799AN to protrude out of the lever 50383BS by 6mm and lock in place with nut 95250.

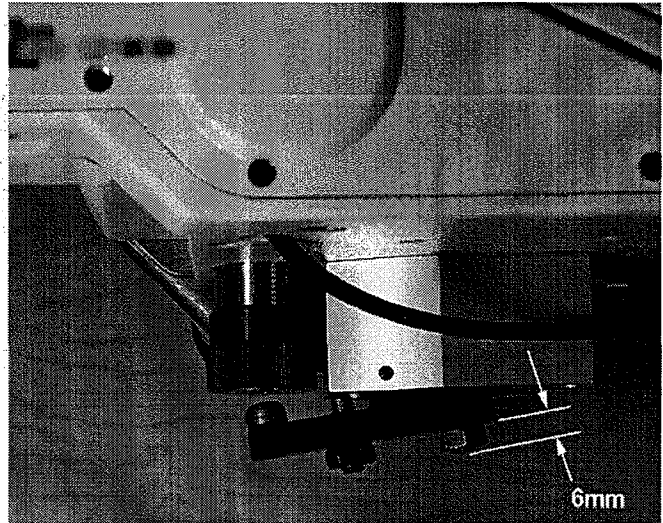

## ADJUSTMENTS FOR STANDARD SEWING

With the air turned on @ 60 psi the differential stitch condensing lever should be engaged while the main cylinder 50329S is disengaged.

The main feed stitch is adjusted as a standard machine.

To adjust the differential standard stitch, turn the left toggle screw out to get more differential feed and in to get less. Turning it out allows the clamp plunger to press in the differential feed knob which increases the differential feed. Lock the toggle screw in place with nut 95250.

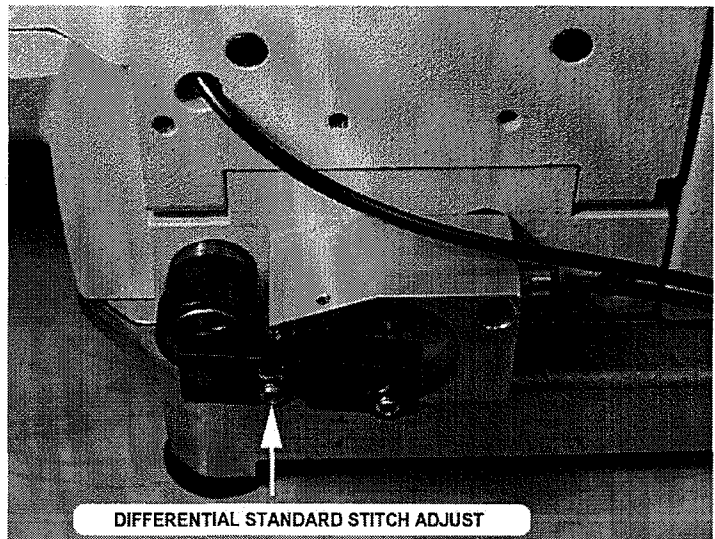



## ADJUSTMENTS FOR STITCH CONDENSING STITCH

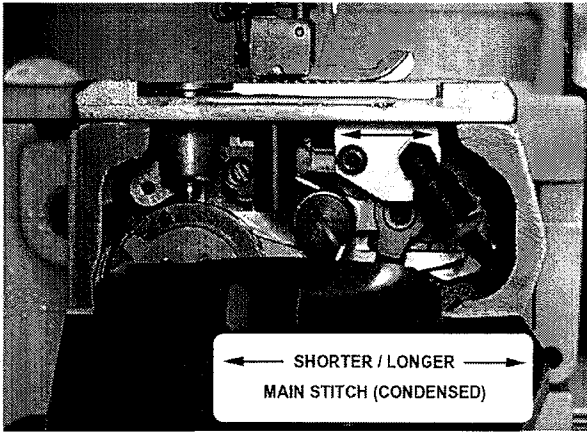

With the stitch condensing mechanism engaged, cylinder assembly 50329S is engaged while 50329T mechanism is disengaged. Make adjustments in this position.

To adjust the main feed to stitch condense at a shorter stitch range, loosen the (2) 22564 screws holding 50329S and move the cylinder. Rearward away from the operator will decrease the number of stitches.

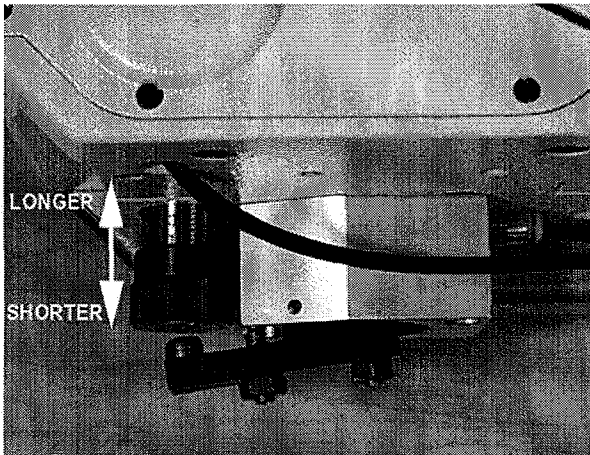

Adjust the differential (when stitch condensing) to match the main. Adjust the knob 50337AP clockwise (in) for a longer stitch.

The recommended stitches for stitch condensing is 5 stitches in 1/4".

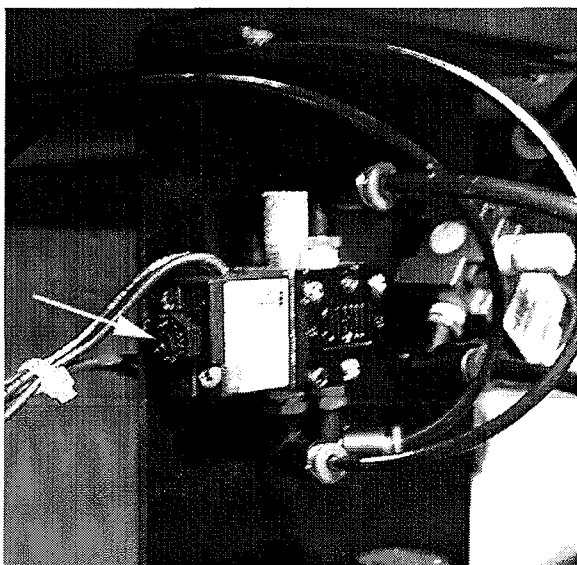

NOTE: The "MAC" valve 29480ASN that is supplied by Union Special has a manual firing button that will allow you to lock the mechanism in the engaged position for adjusting.



## ADJUSTMENTS FOR STANDARD SEWING

For proper function of the stitch condense mechanism the motor must have the capability to do the following.

- 1) Two position needle, down/up, (optional single position up).
- 2) Two position heal, 1st. presser foot up and 2nd. end of seam stitch condensing/trim.
- 3) Motor run signal for chip disposal system. If required
- 4) Trimmer/Safety Switch/Presser Foot Lift.
- 5) Stitch Condensing
  - a) with adjustable speed ( 250 to 2000 rpm), standard setting 1500rpm.
  - b) with adjustable number of stitches (0 to 25 stitches), standard setting 5 stitches.
- 6) By-pass stitch condensing during sewing, (optional with trim).
- 7) Presser Foot locked up after trim (optional)

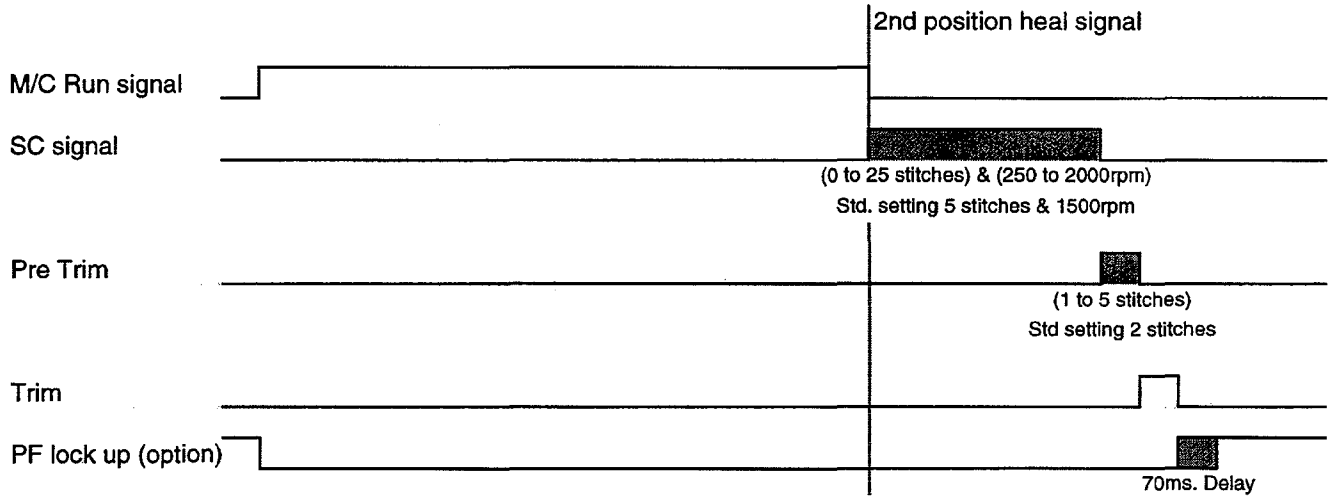

NOTE: Adjusting when the stitch condense mechanism is engaged is totally independent of when it is disengaged and will not effect the standard sewing stitch.

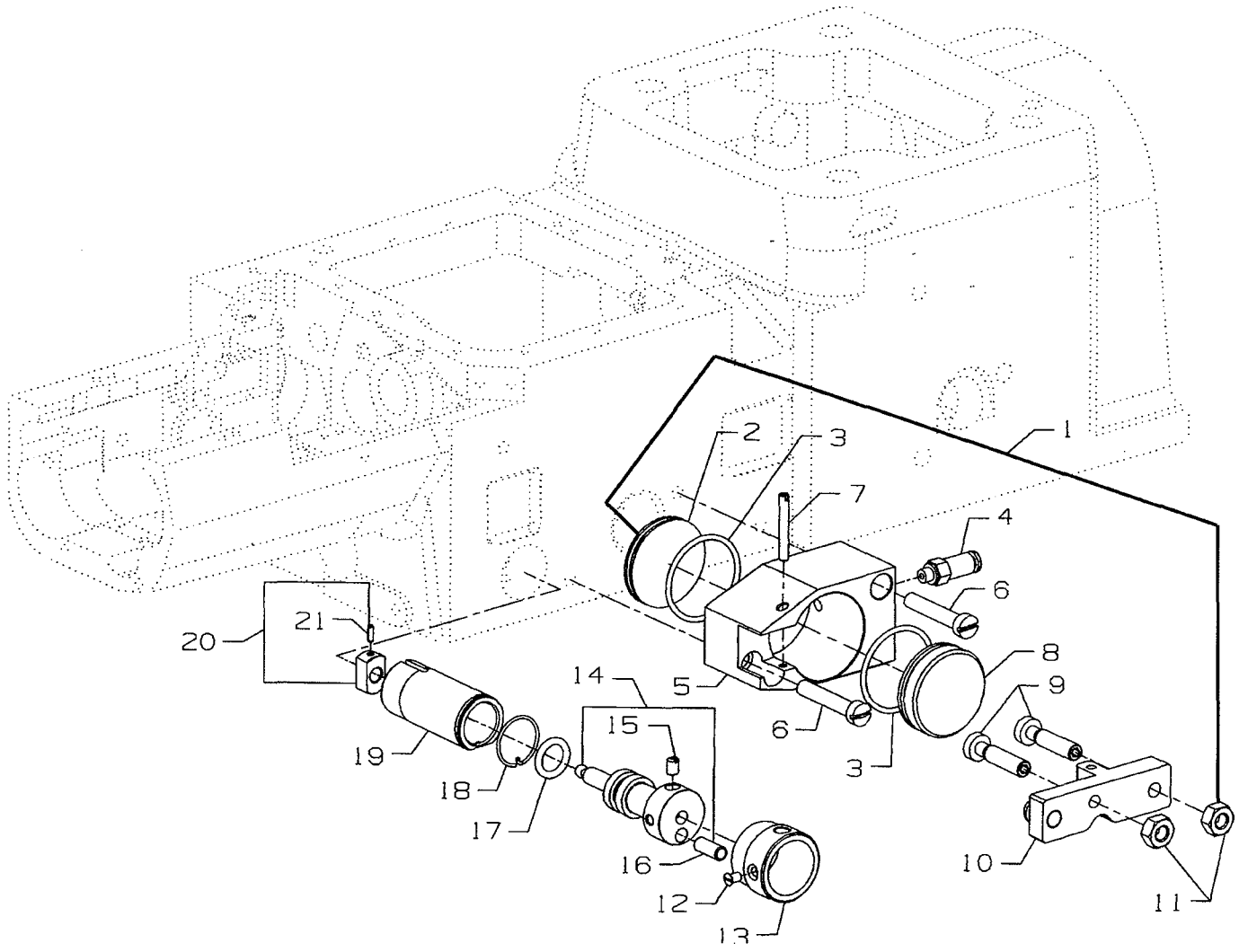

DIFFERENTIAL FEED ACTIVATE, AIR CYLINDER

Ref. No.	Part No.	Description	Amt. Req.
1.	50329T	Differential Feed Activate, Air Cylinder .....	1
2.	99683VK3	Plug .....	1
3.	660-969	"O"Ring .....	2
4.	671F82G	Air Fitting .....	1
5.	50383BR	Air Cylinder Housing .....	1
6.	22517A	Screw .....	1
7.	22799K	Screw .....	1
8.	50382KH	Plunger .....	1
9.	22799AN	Toggle Screw .....	2
10.	50383BS	Clamp .....	1
11.	95250	Nut .....	2
12.	77K	Screw .....	1
13.	34336TA	Bushing .....	1
14.	34336HB	Adjusting Screw .....	1
15.	22560B	Screw .....	1
16.	96531	Pin .....	1
17.	999-211P	"O" Ring .....	1
18.	34336MC	Retaining Ring .....	1
19.	34336MB	Bushing .....	1
20.	34336LA	Nut .....	1
21.	96653	Pin .....	1

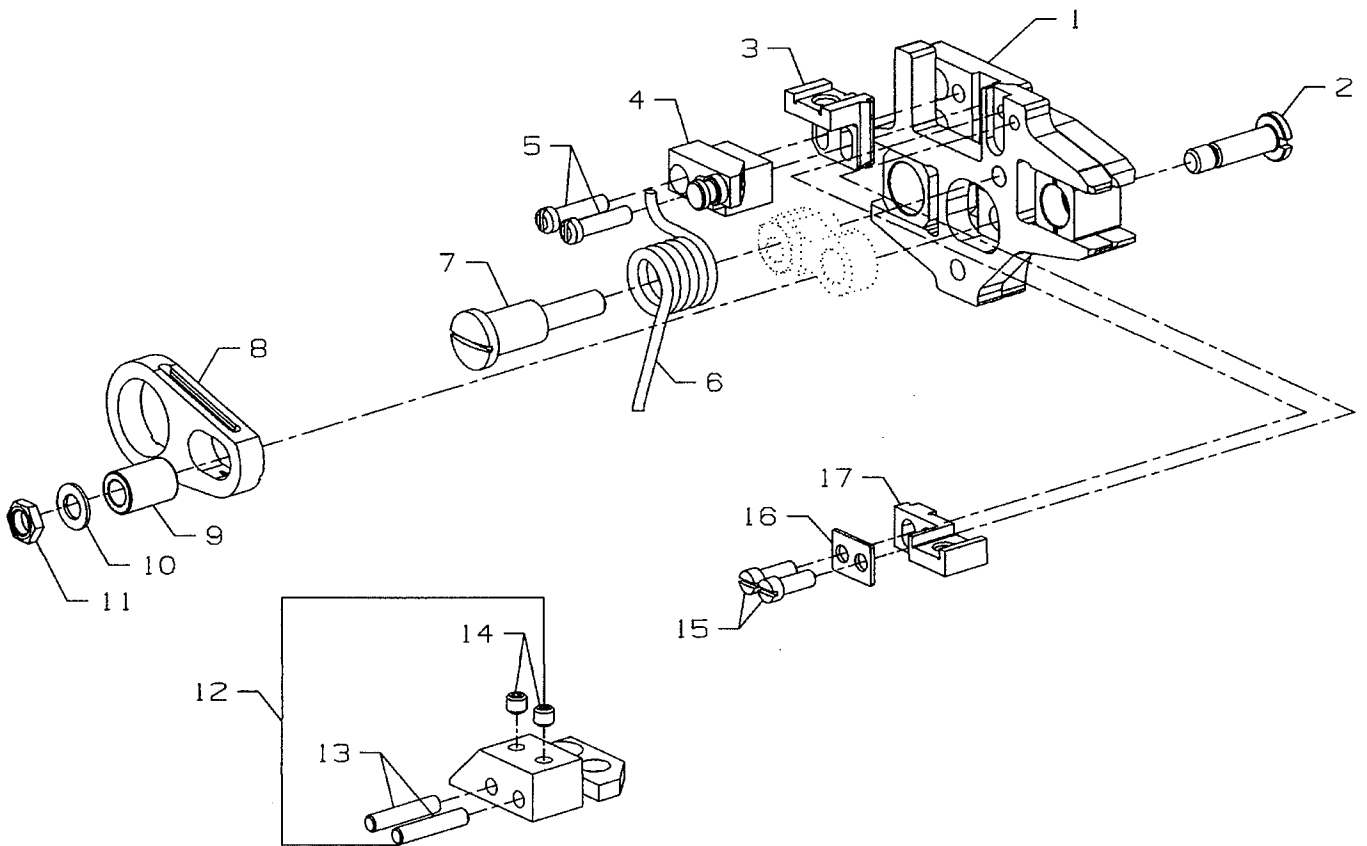

## FEED BAR ASSEMBLY

Ref. No.	Part No.	Description	Amt. Req.
1.	29476SH	Feed Bar Assembly .....	1
2.	50395Z	Screw .....	1
3.	34353	Main Feed Dog Holder .....	1
4.	50383BN	Mounting Block .....	1
5.	22747B	Screw .....	2
6.	50332AW	Spring .....	1
7.	22768M	Screw .....	1
8.	50335BH	Connector .....	1
9.	39536C	Bushing .....	1
10.	1185L	Washer .....	1
11.	12934A	Nut .....	1
12.	50362Y	Retainer .....	1
13.	670B10	Pin .....	2
14.	22894AY	Set Screw .....	2
15.	77B	Screw .....	2
16.	50386L	Washer Plate .....	1
17.	34353A	Differential Feed Dog Holder .....	1

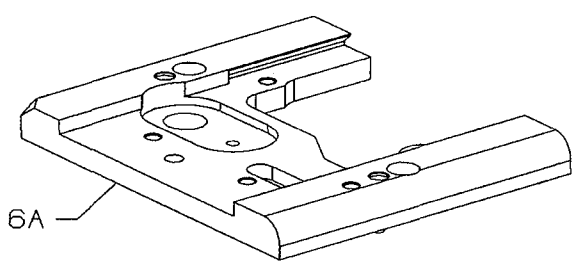
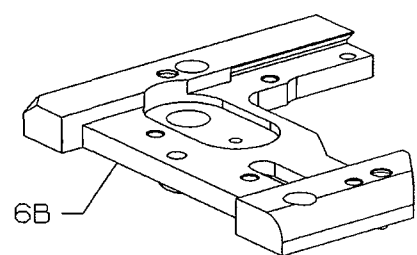
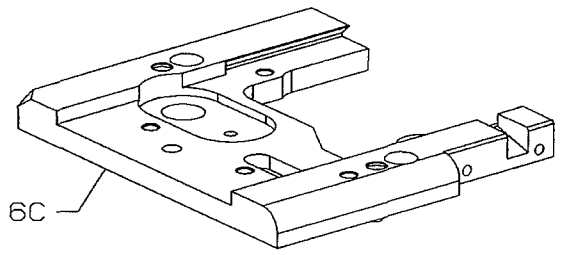
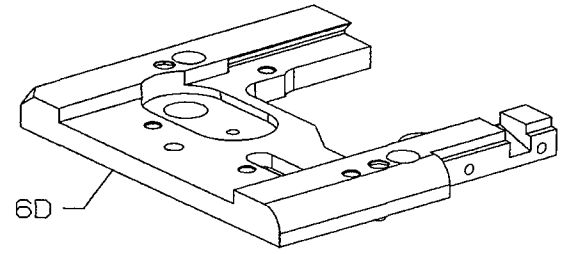
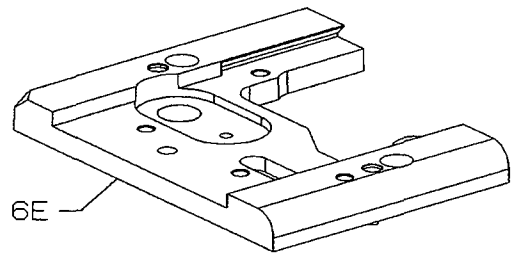
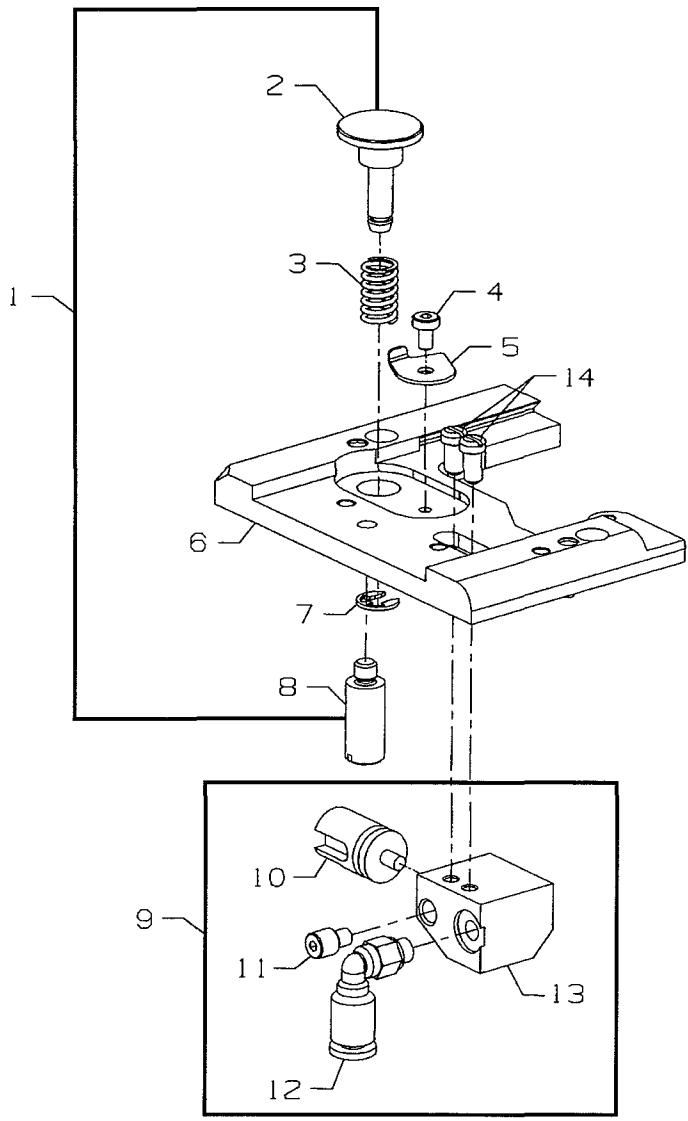

THROAT PLATE SUPPORT ASSEMBLY  
&  
AIR CYLINDER ASSEMBLY

Ref. No.	Part No.	Description	Amt. Req.
1.	29476YM	Throat Plate Support Assembly, for styles E11 .....	1
-	29476YT	Throat Plate Support Assembly, for styles H01 .....	1
-	29476YU	Throat Plate Support Assembly, for styles H21 .....	1
-	29476YV	Throat Plate Support Assembly, for styles K01 .....	1
-	29476YW	Throat Plate Support Assembly, for styles K02 .....	1
-	29476YX	Throat Plate Support Assembly, for styles U06 .....	1
2.	34367	Stop Bolt .....	1
3.	97014	Spring .....	1
4.	95685	Screw .....	1
5.	34367B	Safety Catch .....	1
6.	34780K	Throat Plate Support, for styles E11 .....	1
6A.	34380V	Throat Plate Support, for styles H01 .....	1
6B.	34380U	Throat Plate Support, for styles H21 .....	1
6C.	34780L	Throat Plate Support, for styles K01 .....	1
6D.	34780M	Throat Plate Support, for styles K02 .....	1
6E.	34380W	Throat Plate Support, for styles U06 .....	1
7.	96277	Retaining Ring .....	1
8.	99364L	Shank Screw .....	1
9.	50329S	Air Cylinder Assembly .....	1
10.	50382KJ	Plunger .....	1
11.	22894AT	Screw .....	1
12.	671F82F	Elbow Fitting .....	1
13.	50383BT	Housing .....	1
14.	22562A	Screw .....	2
15.	29480ASN	Pneumatic Control (not shown) .....	1
16.	6-878-4mm-.65mm	Tubing (1m) .....	1

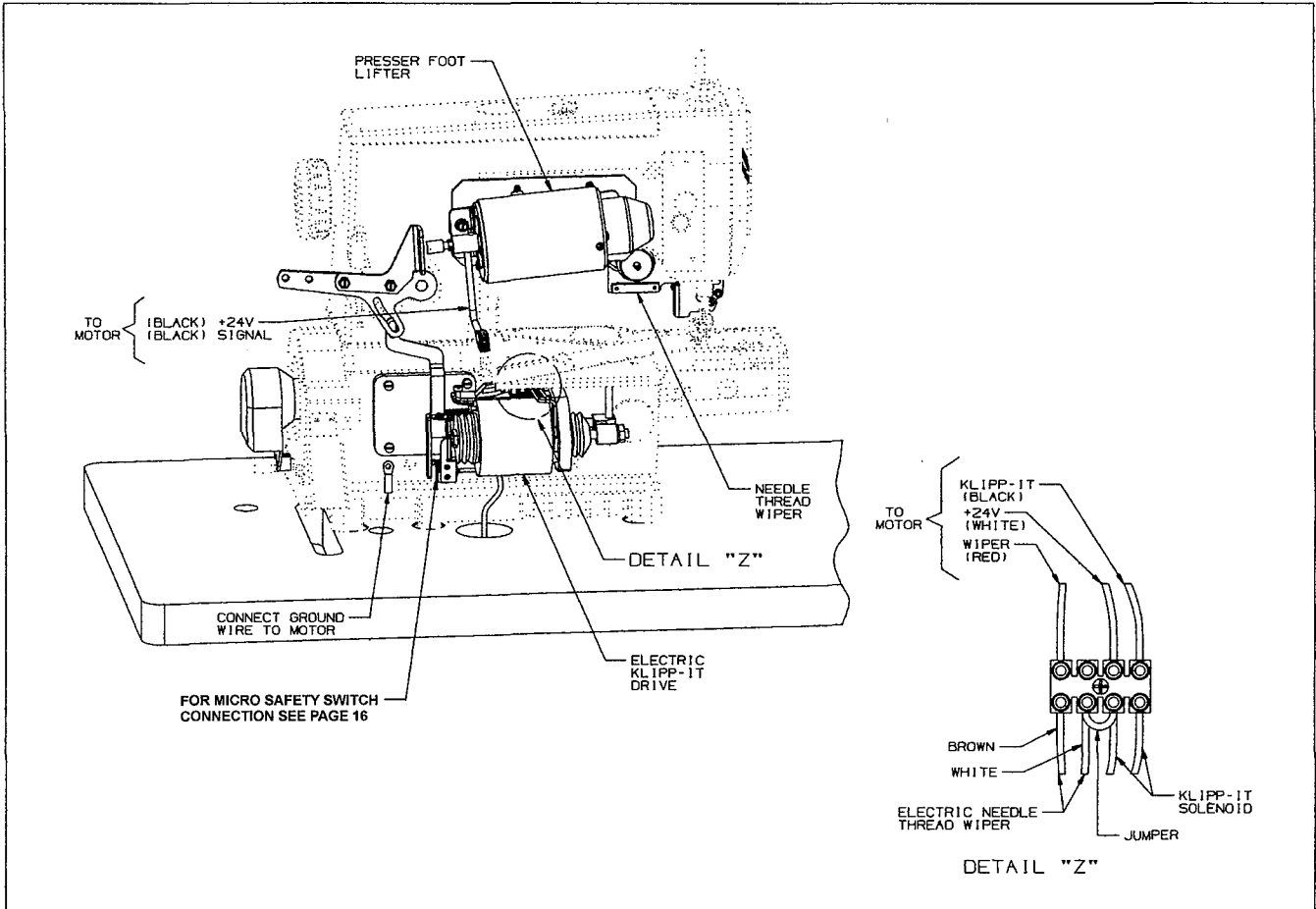



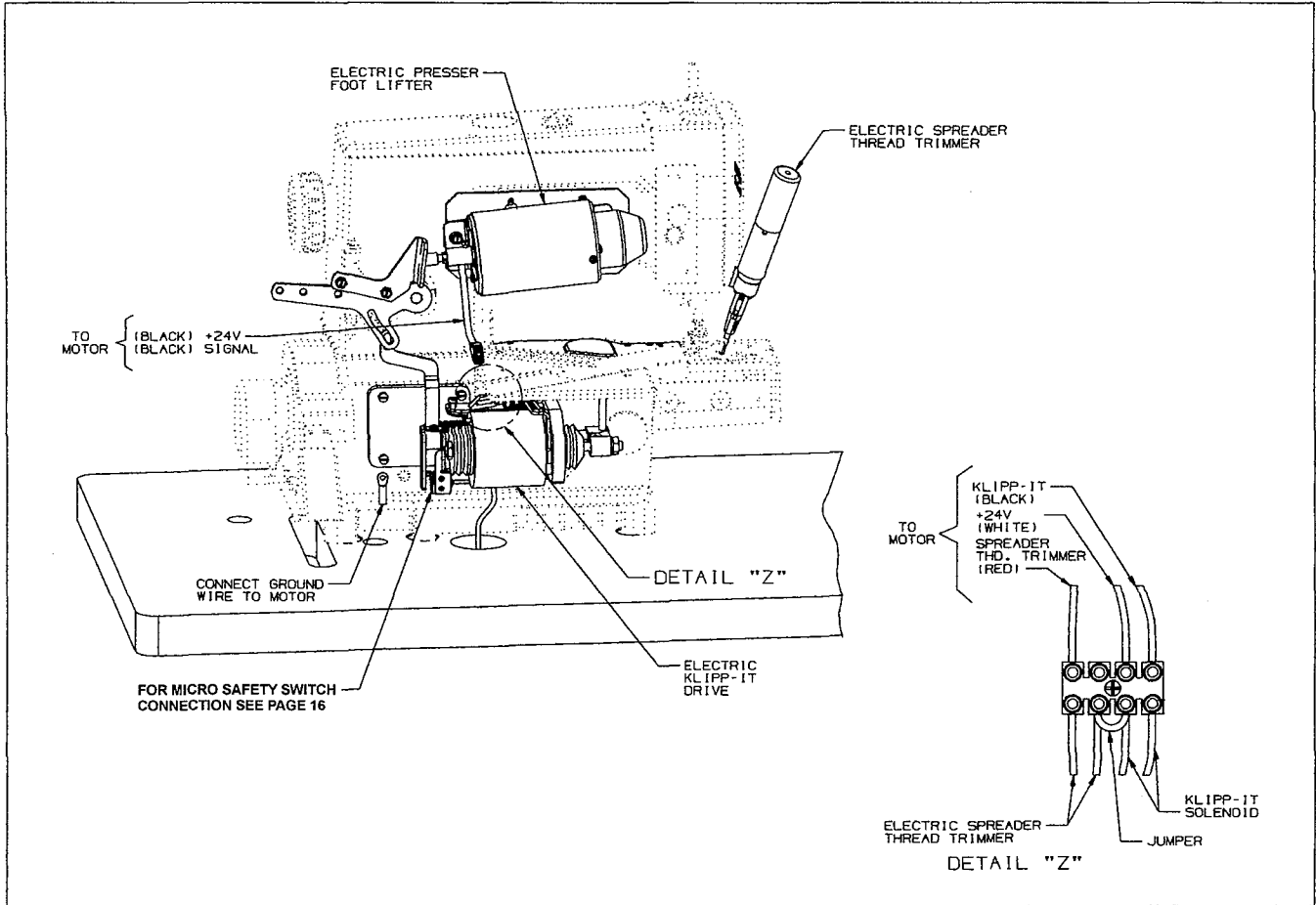

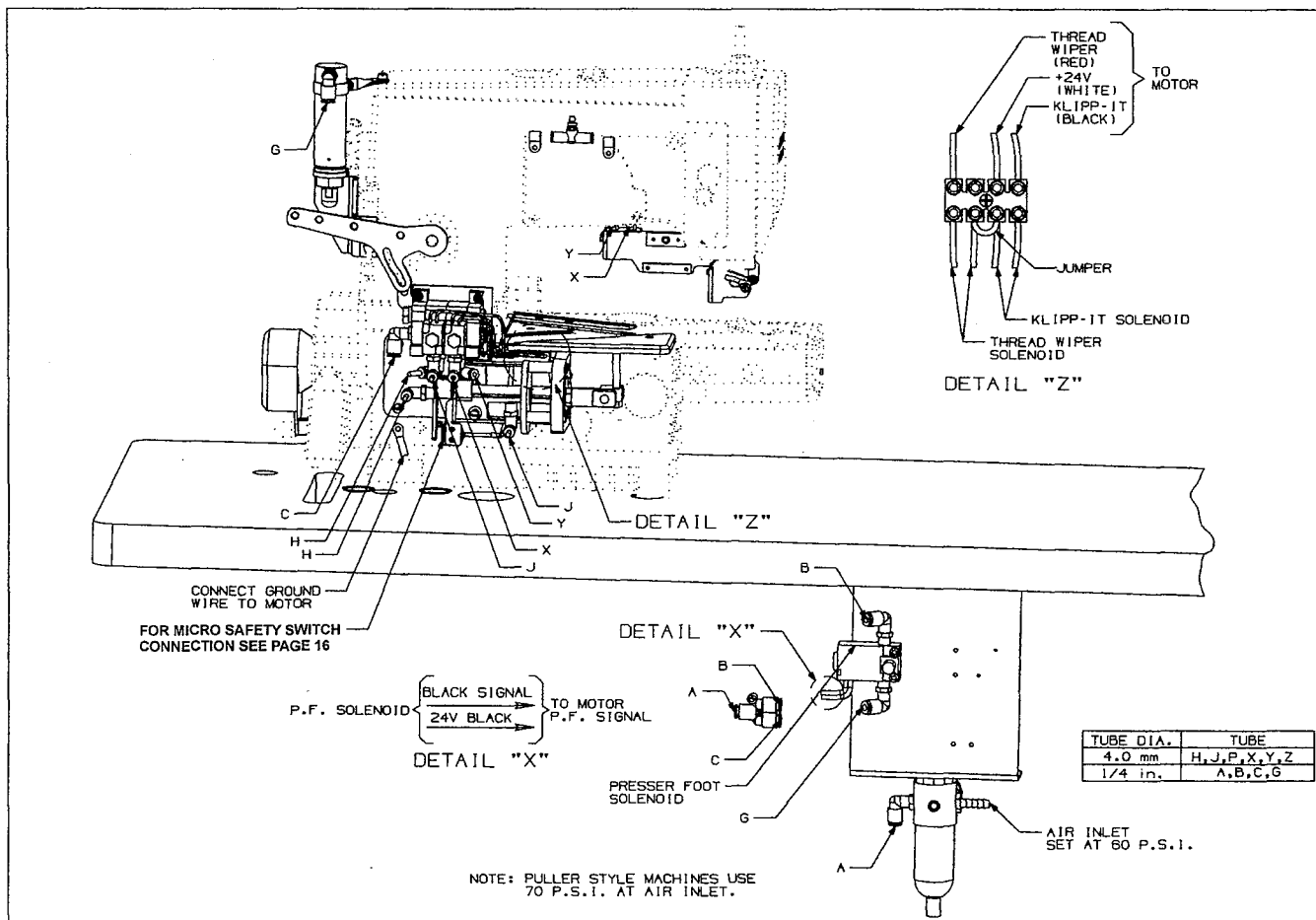

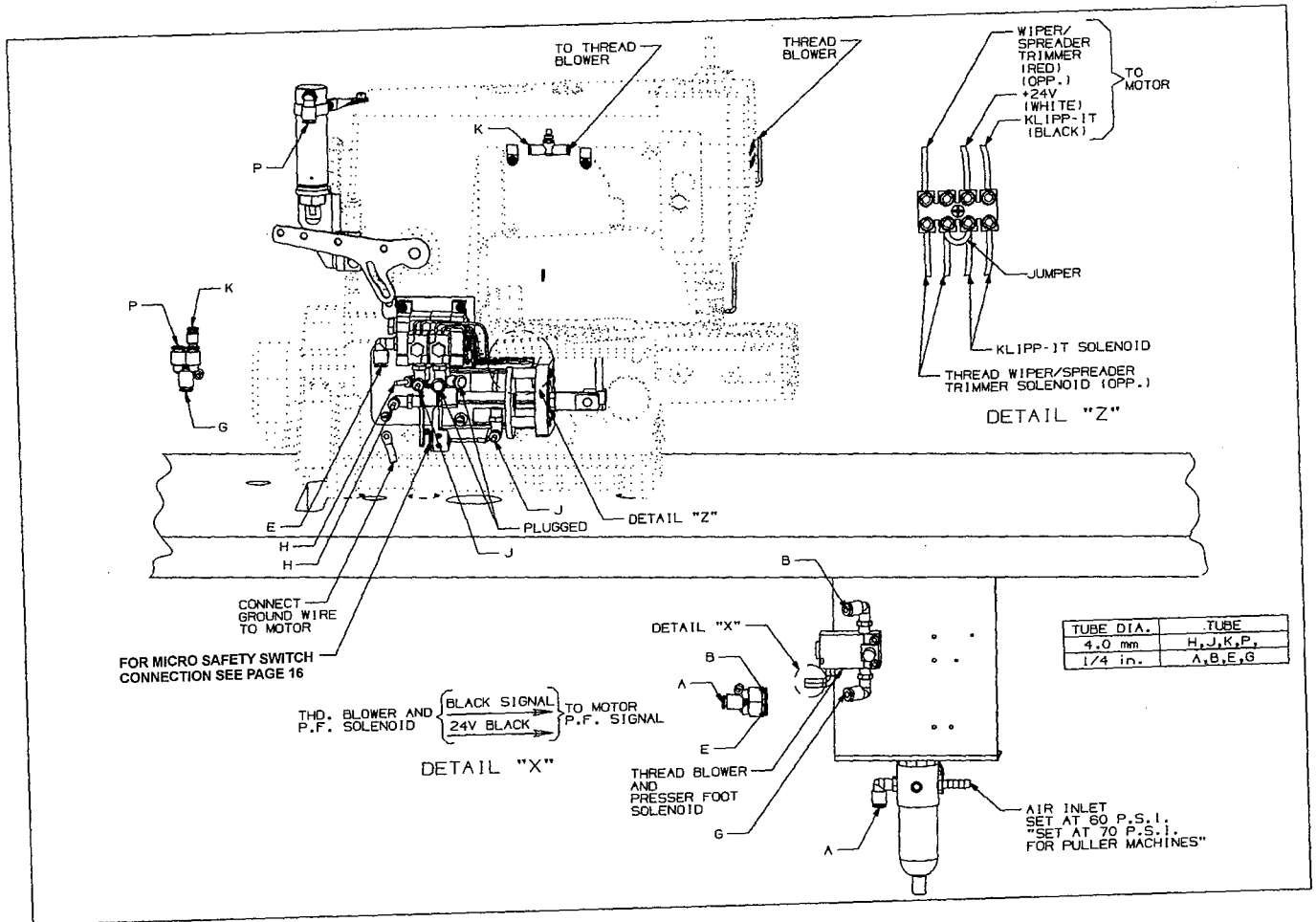

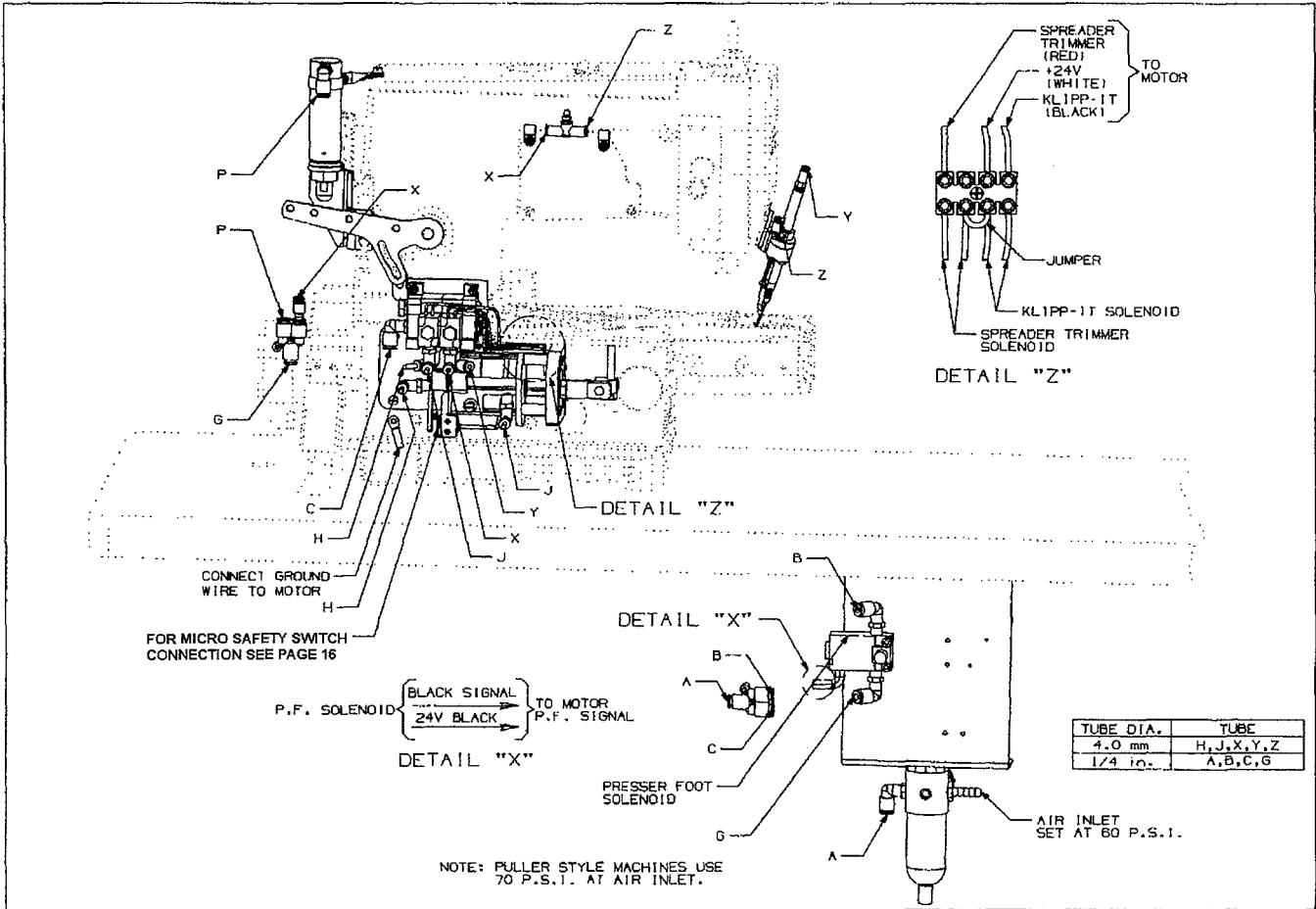

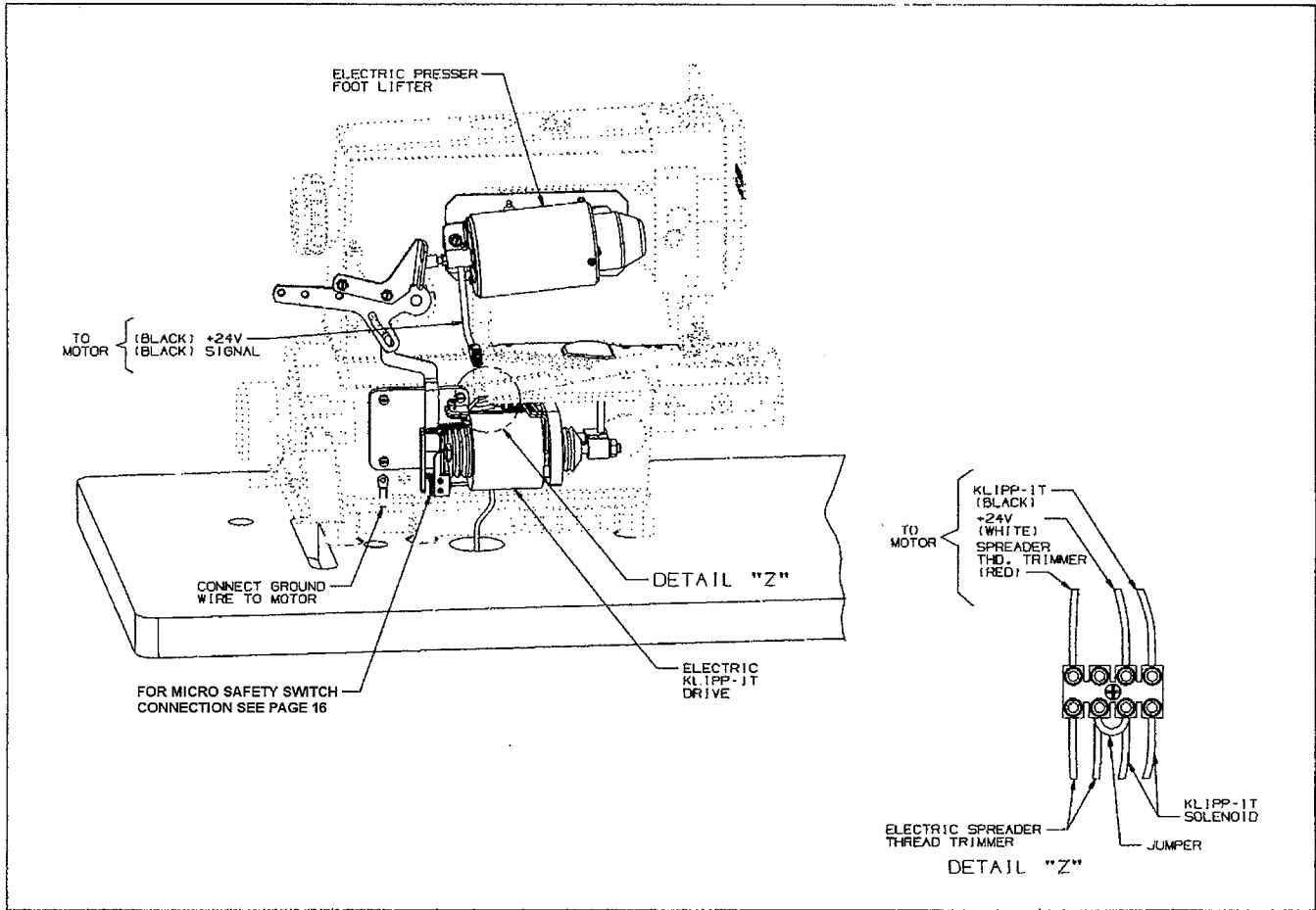

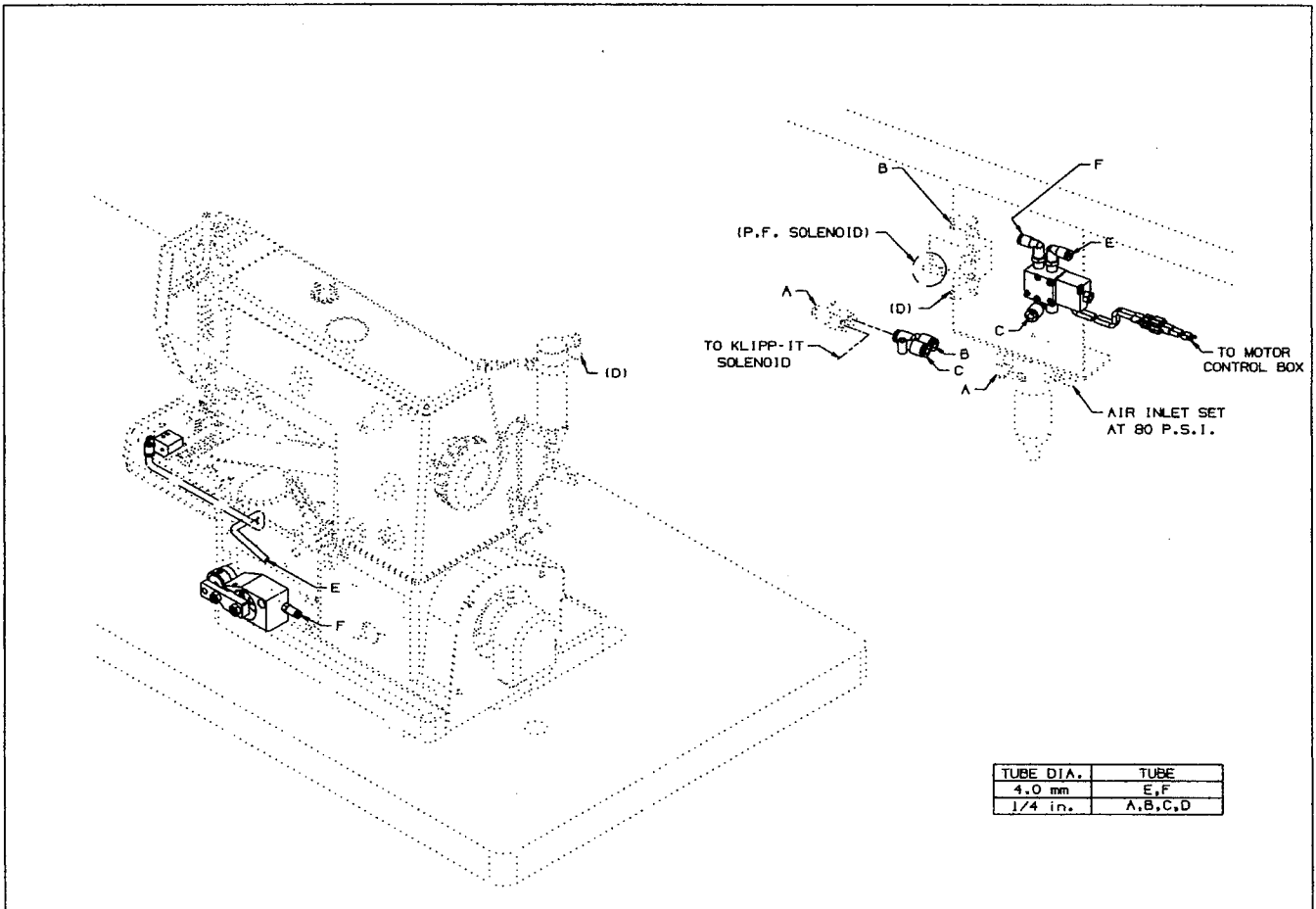



## NUMERICAL INDEX OF PARTS

<u>Part No.</u>	<u>Page No.</u>	<u>Part No.</u>	<u>Page No.</u>	<u>Part No.</u>	<u>Page No.</u>	<u>Part No.</u>	<u>Page No.</u>
1185L .....	61	29980LD .....	45	50335BH .....	61	53636C .....	27
12934A .....	61	29980LE .....	33	50337AX .....	25	55235E .....	31, 37
1318001 .....	31, 37	34336HB .....	59	50349F .....	33, 45	56392G .....	23
14076 .....	31, 37	34336LA .....	59	50357AT .....	25	56392H .....	23
18-1449 .....	25	34336MB .....	59	50357AU .....	25	56392L .....	23
18-1453 .....	25	34336MC .....	59	50357AV .....	25	56392M .....	23
18-1472 .....	25	34336TA .....	59	50357AW .....	25	57865 .....	23
18-1473 .....	25	34353 .....	61	50357AX .....	25	57892K .....	23
18-1474 .....	25	34353A .....	61	50358Y .....	23	6-878-4mm-.65mm ...	37
18C1481 .....	25	34367 .....	63	50362B .....	29, 39	6-878-4mm-.65mm ...	39
21233FB .....	37	34367B .....	63	50362Y .....	61	6-878-4mm-.65mm ...	43
22513B .....	31, 37	34380U .....	63	50363BF .....	29, 39	6-878-4mm-.65mm ...	45
22517A ...	31, 37, 59	34380V .....	63	50366L .....	25	60078Z .....	31, 37
22560B .....	59	34380W .....	63	50367H .....	27	660-1099 .....	41
22562A .....	63	34382AC .....	25	50368AE .....	25	660-1105 .....	45
22569B .....	31, 37	34749P .....	25	50370H .....	33, 45	660-403 .....	35
22585 .....	25	34750P .....	25	50372C .....	33, 45	660-763 .....	37
22596 .....	23	34750R .....	25	50372D .....	33, 45	660-969 .....	59
22731 .....	33, 45	34750SA .....	25	50373DG .....	31, 37	666-330 .....	23
22735 .....	23	34750T .....	25	50374A .....	23	670B10 .....	61
22738D .....	31, 37	34750U .....	25	50374K .....	41	670E1302 ...	31, 37
22747B .....	61	34751MS .....	25	50382KH .....	59	670E1508 .....	31
22757 .....	23	34751MT .....	25	50382KJ .....	63	670E1541 ...	31, 37
22768M .....	61	34752M .....	25	50383AF .....	41	670E1542 ...	31, 37
22799AN .....	59	34752N .....	25	50383AR .....	41	670G276 .....	37
22799K .....	59	34763P .....	25	50383AS .....	33, 45	670K15 .....	29
22852A .....	31, 37	34768A .....	25	50383AT .....	33, 45	670K28 .....	31
22894AT .....	63	34768C .....	25	50383BK .....	31, 37	670K29 .....	27
22894AX .....	37	34769B .....	25	50383BN .....	61	670K85 .....	33
22894AY .....	61	34770M .....	25	50383BR .....	59	671-103B .....	37
28C .....	23	34773D .....	25	50383BS .....	59	671-104A .....	37
29105BP .....	45	34773E .....	25	50383BT .....	63	671-168 .....	43
29105BR .....	33	34773F .....	25	50383N .....	37	671-50 .....	35
29476SH .....	61	34780K .....	63	50383S .....	27	671-B23 .....	41
29476YM .....	63	34780L .....	63	50386L .....	61	671A360 .....	41
29476YT .....	63	34780M .....	63	50392AN .....	23	671A363 .....	45
29476YU .....	63	34794A .....	25	50392AP .....	23	671B182 .....	35
29476YV .....	63	35032H .....	27	50392AR .....	23	671B23 .....	35
29476YW .....	63	35086BJ .....	39	50392AS .....	23	671D42 .....	35
29476YX .....	63	35086BK .....	39	50392AV .....	23	671F81A ...	35, 37
29477NL .....	23	39536C .....	61	50392R .....	23	671F81C ...	35, 41
29480ASU .....	35	50329S .....	55	50392X .....	23	671F82C .....	37
29480ATW .....	37	50329T .....	51	50394AJ .....	43	671F82F ...	45, 63
29480AWU .....	35	50332AB .....	29	50395N .....	27	671F82G ...	45, 59
29480AXJ .....	41	50332AD .....	25	50395P .....	27	671F86B .....	35
29480AYH .....	25	50332AG .....	33, 45	50395R .....	27	671F87 .....	37
29480AYJ .....	25	50332AW .....	61	50395Z .....	61	671F88 .....	35
29906L .....	39	50333B .....	27	51250C .....	29, 39	69H .....	43
29906M .....	29	50333K .....	33, 45	51292F2 .....	31, 37	77A .....	23
29921D .....	27	50333L .....	33, 45	52336B .....	39	77B .....	61



## NUMERICAL INDEX OF PARTS

<u>Part No.</u>	<u>Page No.</u>			
77K .....	<b>59</b>	99650E .....	<b>29</b>	SS6060510TP ... <b>29, 39</b>
80696RA .....	<b>31, 37</b>	99652A .....	<b>39</b>	SS6080610TP .....
90 .....	<b>25</b>	99653B .....	<b>29, 39</b>	SS6110610TP ... <b>33, 45</b>
90561K .....	<b>35</b>	99657E .....	<b>29, 39</b>	SS6110710TP .....
92855A .....	<b>27</b>	99683CP .....	<b>35</b>	SS6111010SP ... <b>31, 37</b>
95167CV .....	<b>39</b>	99683VK3 .....	<b>59</b>	SS6122030SP .....
95169 .....	<b>31</b>	99694A .....	<b>37</b>	SS7060310SP .....
95177 .....	<b>31</b>	99697AA ....	<b>29, 39</b>	SS706310SP .....
95179K .....	<b>31</b>	998-297A .....	<b>31, 37</b>	SS7090510SP .....
95250 .....	<b>59</b>	998-306B .....	<b>31</b>	SS7090520SP .....
95251 .....	<b>31</b>	998-358E .....	<b>31, 37</b>	SS7090610SP ... <b>29, 39</b>
95259 .....	<b>39</b>	999-191H .....	<b>39</b>	SS7121410TP .....
95294 .....	<b>39</b>	999-211P .....	<b>59</b>	SS8080610SP ... <b>33, 45</b>
95411 .....	<b>37</b>	999-411M5-4 .....	<b>39</b>	SS8110520TP ... <b>33, 45</b>
95415 .....	<b>35</b>	A9858 .....	<b>23</b>	SS9111010SP .....
95685 .....	<b>63</b>	B3101804000 .....	<b>23</b>	SS9120910TP ... <b>29, 39</b>
95951 .....	<b>27</b>	B3103804000 .....	<b>23</b>	SS9151420TP .....
95956 .....	<b>39</b>	B3112704000 .....	<b>23</b>	WPO450846SP ... <b>33, 45</b>
96150 .....	<b>29, 39</b>	B3120352000 .....	<b>23</b>	WSO410002KP .....
96151 .....	<b>31, 37</b>	B3121804000 .....	<b>23</b>	WSO510002KP ... <b>27, 41</b>
96161 .....	<b>29, 39</b>	B3126012000 .....	<b>23</b>	WSO631510KP .....
96261 .....	<b>31, 37</b>	G51346KA .....	<b>23</b>	
96277 .....	<b>63</b>	G52882KW ...	<b>31, 37</b>	
96280 .....	<b>29, 39</b>	GAK33034000 .....	<b>27</b>	
96531 .....	<b>59</b>	GAK3303600A .....	<b>27</b>	
96653 .....	<b>59</b>	GAK8403000A .....	<b>27</b>	
96711 .....	<b>23</b>	HK034610020 .....	<b>35</b>	
96721 .....	<b>31, 37</b>	HK03464000B .....	<b>35</b>	
97014 .....	<b>63</b>	NS6080210SP ...	<b>33, 45</b>	
99296 .....	<b>23</b>	NS6110420SP .....	<b>23</b>	
99327 .....	<b>37</b>	NS6120310SP .....	<b>41</b>	
99358 .....	<b>29, 39</b>	NS6150430SP .....	<b>27</b>	
99364L .....	<b>63</b>	NS6660430SP .....	<b>27</b>	
99545F .....	<b>39</b>	PH0300062CO ...	<b>33, 45</b>	
99545G .....	<b>29, 39</b>	PH0300083UO ...	<b>29, 39</b>	
99545H .....	<b>29, 39</b>	RE025000KO .....	<b>25</b>	
99591DH .....	<b>37</b>	RM2871B .....	<b>31, 37</b>	
99591DN .....	<b>29, 39</b>	SD0600176SP .....	<b>25</b>	
99591DP .....	<b>29</b>	SM1020450TP .....	<b>25</b>	
99613D .....	<b>31, 37</b>	SM5030355SN .....	<b>25</b>	
99614D .....	<b>31, 37</b>	SM6020250TP .....	<b>25</b>	
99615 .....	<b>31, 37</b>	SM6020600TP .....	<b>25</b>	
99616 .....	<b>31</b>	SS4051281SE .....	<b>27</b>	
99616A .....	<b>37</b>	SS4091015SP ...	<b>29, 39</b>	
99617A .....	<b>31</b>	SS4120615SP .....	<b>43</b>	
99617T .....	<b>37</b>	SS4120915SP .....	<b>45</b>	
99619 .....	<b>31, 37</b>	SS4121015SP .....	<b>41</b>	
99620 .....	<b>23</b>	SS4121415SP .....	<b>37</b>	
99646J .....	<b>29, 39</b>	SS4121915SP .....	<b>33</b>	
99650D .....	<b>39</b>	SS6060210SP ...	<b>29, 39</b>	





Union Special Corporation  
Corporate Office  
One Union Special Plaza  
Huntley, IL 60142  
Phone: 847•669•5101  
Fax: 847•669•4454

Union Special GmbH  
European Distribution Center  
Raiffeisenstrasse 3  
D-71696 Möglingen, Germany  
Tel: 49•07141•247•0  
Fax: 49•07141•247•100

JUKI CORPORATION  
INTERNATIONAL SALES DIVISION  
8-2-1, KOKURYO - CHO,  
CHOFU-SHI, TOKYO 182, JAPAN  
PHONE: 03(3430)4001~5  
FAX: 03(3430)4909 . 4914 . 4984



**JUKI**  
*Union Special*